

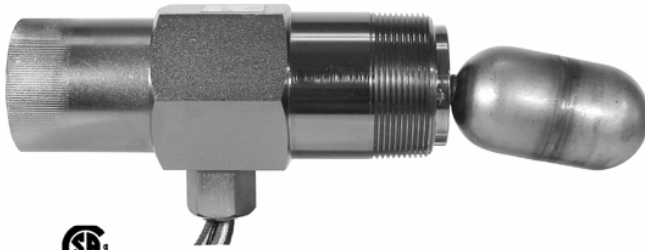

**Electric Switch**



  
Pending

**Pneumatic Switch**

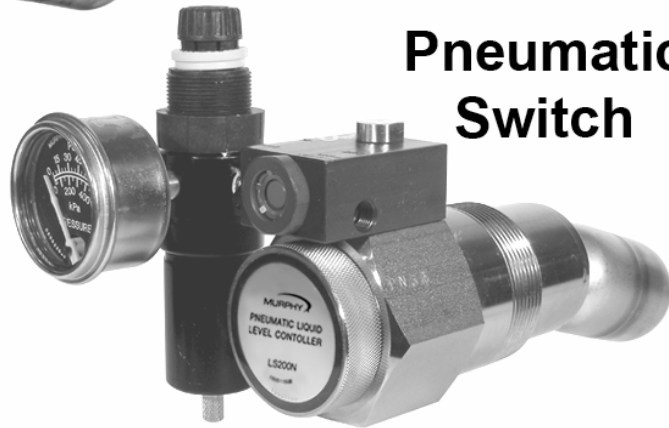

# **LS200, LS200N, LS200NDVOR Series and L1100 Liquid Level Switches**

## ***Installation and Operations Manual***

---

00-02-0614  
03-05-08  
Section 15

In order to consistently bring you the highest quality, full featured products, we reserve the right to change our specifications and designs at any time. The latest version of this manual can be found at [www.fwmurphy.com](http://www.fwmurphy.com).

**Warranty** - A limited warranty on materials and workmanship for one year is given with this FW Murphy product. A copy of the warranty may be viewed or printed by going to [www.fwmurphy.com/support/warranty.htm](http://www.fwmurphy.com/support/warranty.htm)



CAUTION: LS200 Series parts are not interchangeable with other Murphy liquid level products. Damage caused by using incorrect parts is not covered by our Limited Warranty.



Please read the following information before installing. A visual inspection for damage during shipping is recommended before mounting.

**BEFORE BEGINNING INSTALLATION OF THIS MURPHY PRODUCT:**

- Disconnect all electrical power to the machine.
- Make sure the machine cannot operate during installation.
- Follow all safety warnings of the machine manufacturer.
- Read and follow all installation instructions.
- OBSERVE all pressure and electrical ratings and requirements for the devices and the operating environment.
- BE SURE all pressure HAS BEEN REMOVED from the vessel before opening any pressure connections.
- Please contact FW MURPHY immediately if you have any questions.

## Table of Contents

|  |           |
|--|-----------|
| <b>Product Information</b> .....                                   | <b>1</b>  |
| Features .....   | 1         |
| LS200, L1100.....  | 1         |
| LS200NDVOR.....  | 2         |
| LS200NDVO .....  | 3         |
| LS200N .....   | 3         |
| <b>Pressure Vessel Installation: LS200, LS200N and L1100</b> ..... | <b>4</b>  |
| Direct Installation into the Wall of the Pressure Vessel .....     | 4         |
| Installation with a Weld Collar .....                              | 5         |
| Installation Using Murphy External Float Chamber .....             | 5         |
| Installation and Adjustment for Pneumatic Models.....              | 6         |
| Trip Cam Operating Lever Orientation .....                         | 7         |
| <b>Replacing and Installing the DVO Assembly</b> .....             | <b>8</b>  |
| Models LS200NDVO & LS200NDVOR .....                                | 8         |
| <b>Electrical</b> .....  | <b>11</b> |
| <b>Replacement Parts</b> .....                                     | <b>11</b> |
| <b>Accessories</b> .....   | <b>12</b> |
| 15050375: Weld Collar.....   | 12        |
| 55050617: DVU150/DVU175 Adapter Bushing.....                       | 12        |
| 15051098: External Float Chamber .....                             | 13        |
| 15051168: CB External Float Chamber .....                          | 13        |
| 15000478: Float Shaft Extension .....                              | 14        |
| <b>Specifications</b> .....  | <b>16</b> |
| All Models.....  | 16        |
| LS200.....   | 16        |
| LS200NDVOR.....  | 16        |
| LS200NDVO .....  | 16        |
| LS200 N .....  | 16        |
| L1100 .....  | 16        |
| Approximate Shipping Weights and Dimensions.....                   | 16        |

**(THIS PAGE INTENTIONALLY LEFT BLANK)**

## Product Information

### Features

- Designed for harsh gas compressor scrubber applications
- 304 stainless steel float operates in 0.5 specific gravity and heavier fluids
- LS200 series rated for 2000 psi (13.8 MPa) [138 bar] working pressure
- Electric and pneumatic models available
- Improved design provides better snap action and dependability with reduced number of moving parts
- All models screw directly into the vessel or can be mounted via external float chamber
- Nickel plated body to provide enhanced corrosion protection
- Improved float connection thread design provides a more secure connection
- Listed for Class I, Div. 1, Grp. C & D locations
- Canadian Registration Number OF1476.2

### LS200, L1100

LS200 Liquid Level Switches with 2" NPT mounting are float activated to operate an electrical SPDT snap switch (optional DPDT on some models) for alarm or shutdown of an engine or electric motor. The LS200 connects directly into the vessel wall and can be used with a weld collar (P/N 15050375) or Murphy external float chamber.

L1100 models (1-1/2" NPT) are also available. Refer to the specification table below for L1100 product dimensions.

|  |          |                    |                   |
|--|----------|--------------------|-------------------|
| <p style="text-align: center;"><b>LS200, L1100</b></p> |          | <b>LS200</b>       | <b>L1100</b>      |
|  | <b>A</b> | 10.16 in. (258 mm) | 11 in. (279 mm)   |
|  | <b>B</b> | 3.44 in. (87 mm)   | 3.50 in. (189 mm) |
|  | <b>C</b> | 1.75 in. (44 mm)   | 1.56 in. (40 mm)  |
|  | <b>D</b> | 2.80 in. (71 mm)   | 3.4 in. (71 mm)   |
|  | <b>E</b> | 2 NPT              | 1-1/2 NPT         |

# LS200NDVOR

LS200NDVOR is a float-activated, pneumatic-vent level device used to operate dump valves or similar devices.

The LS200NDVOR provides a 2" NPT mounting with a pneumatic snap action output for interfacing with pneumatic devices such as our Murphy pneumatic dump valve or with other pneumatic instrumentation.

Pneumatic media devices require clean, dry, instrument quality air or gas. This unit is supplied with a pressure regulator, filter and Murphy 20BPG pressure gage for improved system life and trouble-free operation.

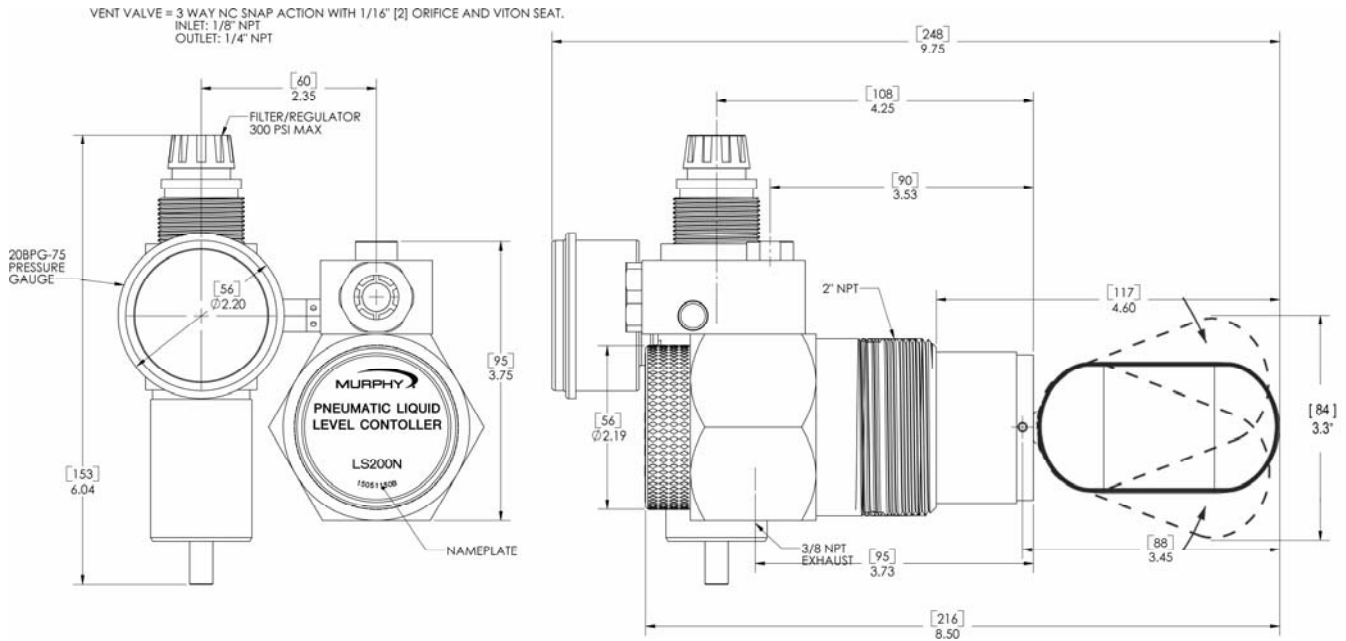

**LS200NDVOR pneumatic level switch with dump valve operator, pressure regulator and gage**

## LS200NDVO

Pneumatic level switch with snap action Dump Valve Operator (DVO) without the pressure regulator for those applications where the system provides a filter regulator for "instrument quality" air or gas as the control medium.

VENT VALVE = 3 WAY NC SNAP ACTION WITH 1/16" [2] ORIFICE AND VITON SEAT.  
INLET: 1/8" NPT  
OUTLET: 1/4" NPT

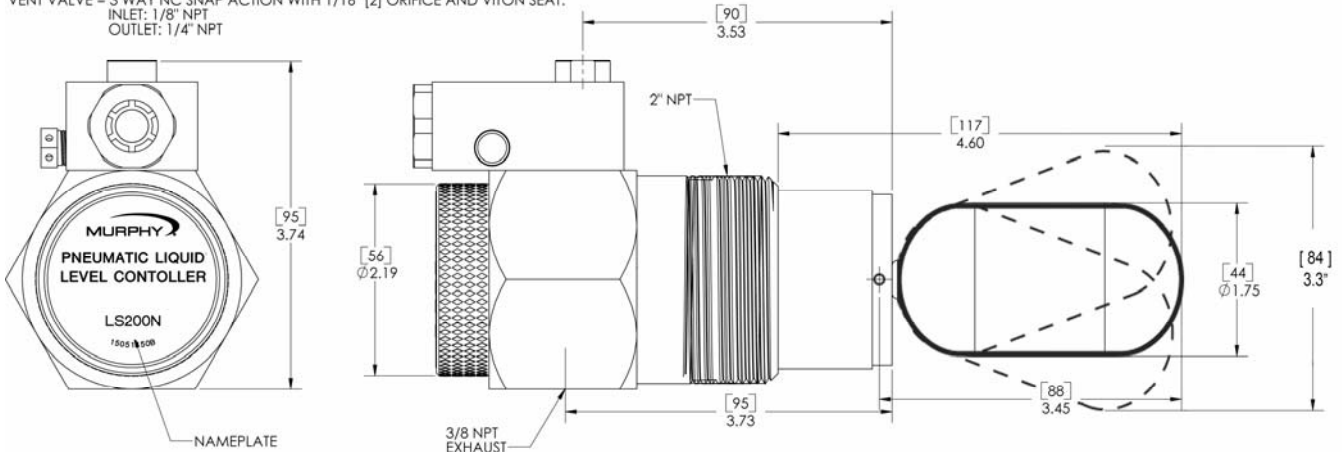

**LS200NDVO pneumatic level switch with dump valve operator**

## LS200N

Pneumatic level switch without the DVO and filter regulator.

VENT VALVE = 2 WAY NC SNAP ACTION WITH 1/16" [2] ORIFICE AND VITON SEAT.  
INLET: 1/8" NPT  
OUTLET: 1/4" NPT

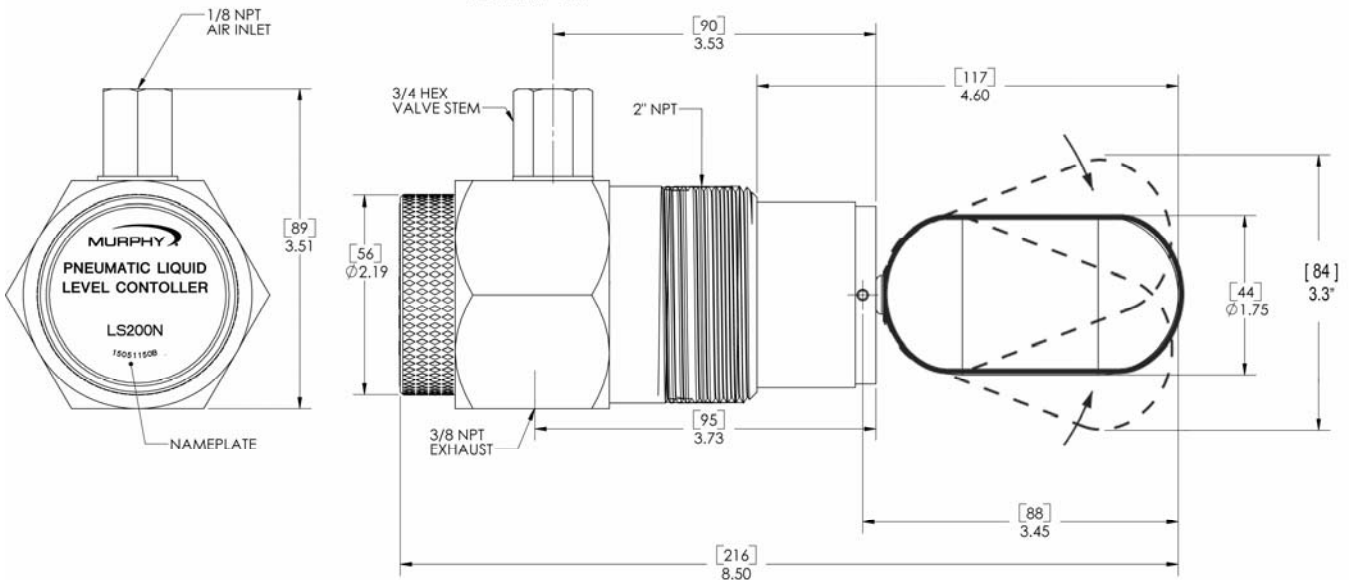

**LS200N pneumatic level switch**

## Pressure Vessel Installation: LS200, LS200N and L1100

### Direct Installation into the Wall of the Pressure Vessel

CAUTION: Determine that the float travel is not obstructed by the coupling in the vessel wall, internal baffles, etc. Do NOT use more than one float shaft extension P/N 15000478.

Refer to the 'Pipe Data' and 'Minimum Clearance' tables below.

1. Make certain the float and extension are tight.
2. Before installing the level switch, use of a pipe thread sealant is recommended. Screw the unit directly into the threaded connection in the wall of the pressure vessel.
3. For LS200 and L1100, verify that the electrical connection is positioned at the bottom.
4. For LS200N the 1/8" NPT pneumatic connection should be on top (the 3/8" NPT vent connection should be on the bottom) for service on a "Trip on Rising" application. The LS200N can be modified for service on a "Trip on Falling" application.
5. Make the electrical wiring connections according to appropriate wiring diagrams for the alarm or shutdown system to be used. The electrical connection is 1/2"-14 NPT.
6. Ensure all electrical connections are insulated and the cover is fully installed before reconnecting electrical power.
7. Verify all pressure connections are tight before pressurizing the system.

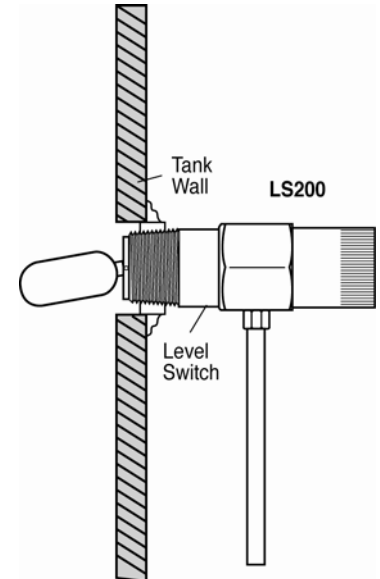

### Clearance Reference Tables

| Pipe Data Table    |               |                 |                         |                          |
|--------------------|---------------|-----------------|-------------------------|--------------------------|
| Nom. Size (inches) | O.D. (inches) | Schedule Number | Wall Thickness (inches) | Inside Diameter (inches) |
| 3                  | 3.5           | 40ST            | 0.216                   | 3.068                    |
| 3                  | 3.5           | 80XS            | 0.3                     | 2.9                      |
| 4                  | 4.5           | 40ST            | 0.237                   | 4.026                    |
| 4                  | 4.5           | 80XS            | 0.337                   | 3.826                    |

| Minimum Clearance Table |                          |                 |                             |                 |
|-------------------------|--------------------------|-----------------|-----------------------------|-----------------|
| Product Name            | Insertion Depth (inches) |                 | Vertical Clearance (inches) |                 |
|                         | Std.                     | w/ 1" Extension | Std.                        | w/ 1" Extension |
| LS 200                  | 4.6                      | 5.6             | 2.8                         | 3.15            |
| LS 200N                 | 5.43                     | 6.4             | 3.3                         | 3.9             |
| L 1200                  | 4.65                     | 5.7             | 3.9                         | 4.55            |
| L 1200N                 | 5.6                      | 6.7             | 5.3                         | 6.9             |
| L 1100                  | 4.4                      | 5.4             | 3.4                         | 4.05            |



## Installation with a Weld Collar

1. The weld collar, P/N 15050375, must be welded into the wall of the pressure vessel according to code standards and good welding practices.
2. Follow above instructions for installation directly into the wall of the pressure vessel.

**NOTE:** Weld collar 15050375 can be used ONLY with model LS200.

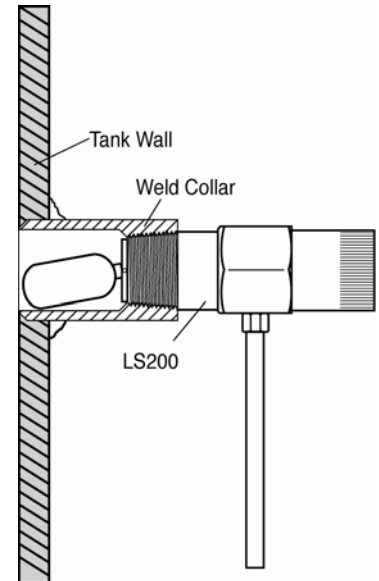

## Installation Using Murphy External Float Chamber

1. Install the Murphy float chamber 15051098 or 15700799 on the outside wall of the pressure vessel using 1" NPT piping or use the mounting surface with a bracket. Position the 2" NPT threaded connection at the height where you want the level switch to operate. The 2" NPT threaded connection must be positioned away from the tank wall.
2. A tee and bleed valve are typically installed at the bottom of the lower 1 inch pipe riser to allow draining of the float chamber for servicing or replacement.

**NOTE:** A typical installation with blocking and bleed valves is shown at right.

3. Install the LS200 or LS200N/NDVO/NDVOR in the 2" NPT connection of the float chamber. BE SURE float travel is not restricted and that the float is tight onto the float shaft.
4. To complete installation and wiring, follow the instructions for mounting directly into wall of the vessel and for wiring.

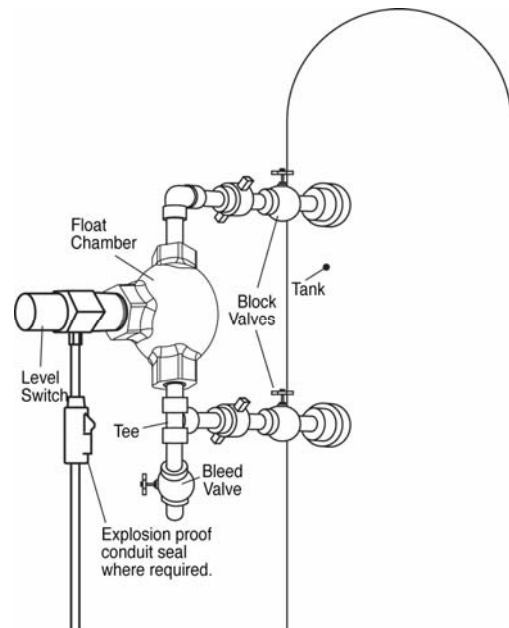

## Installation and Adjustment for Pneumatic Models

1. All pneumatic models operate on the vent principle.

**The pneumatic signal source must be clean and dry “Instrument Quality” air or natural gas.**

**The input pneumatic signal must be regulated between 30 and 70 psi (207-483 kPa) [2 -4.83 bar].** If produced gas is used as the signal source, it should be taken after gas passes through the final scrubber. A suitable filter must be positioned before the LS200NDVO to prevent liquids and/or particulates from entering the dump valve operator.

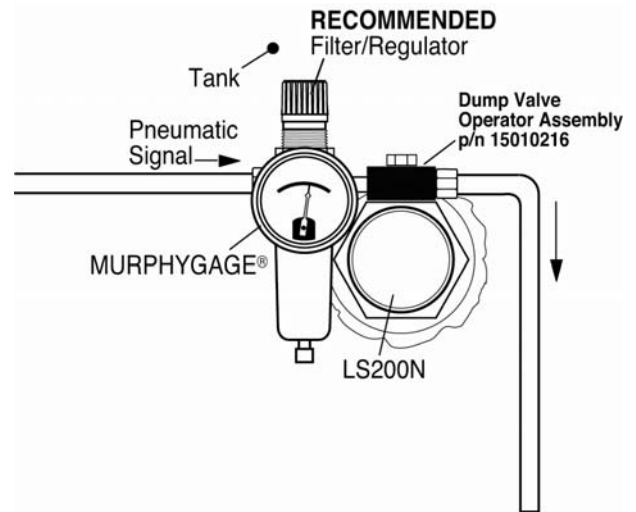

**NOTE:** Check filter periodically for wear and tear and elements that hamper the flow of the pneumatic signal.

2. All pressure connections must be tight and maintained tight so as not to leak air/gas.
3. Valve seat adjustment can be made if air/gas begins to leak. Care should be taken when adjusting as only slight movement is necessary to stop the leakage; excessive force will bind the seating mechanism. See the instruction below for adjustment.

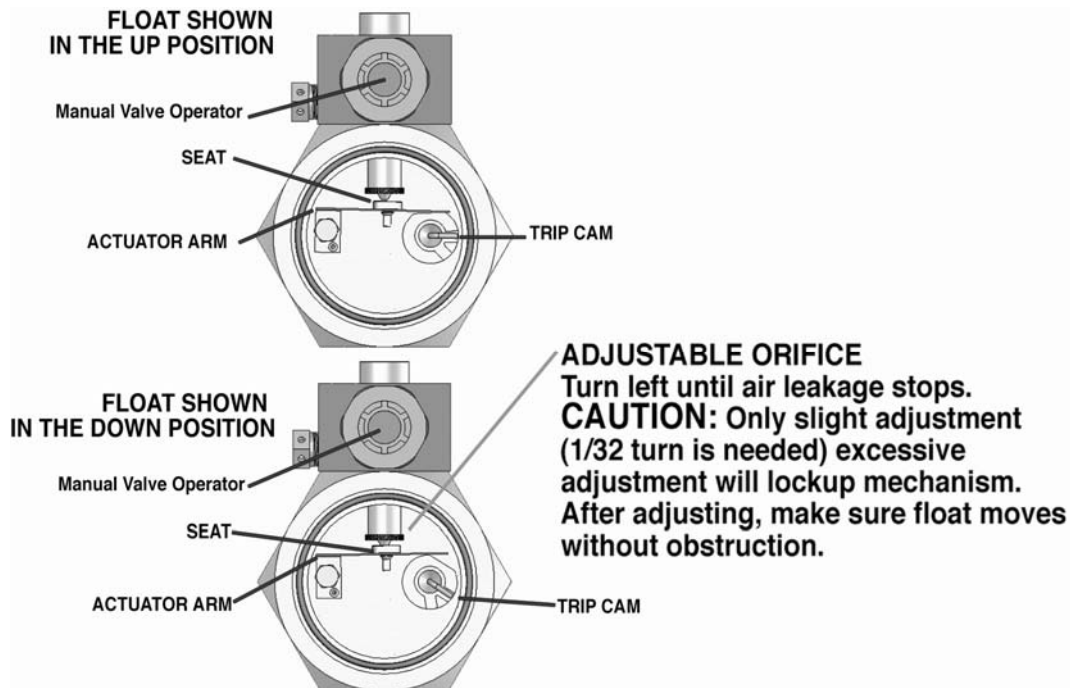

**CAUTION:** Avoid excessive Teflon tape which may inhibit proper operation.

## **Trip Cam Operating Lever Orientation**

---

The LS200 series level switches are shipped with the trip cam orientation set for normal operation, or vent on rising level. If the application requires a vent on falling level, the trip cam operating lever can be moved to the alternate position as indicated in the diagram below. Gently depress the cam and rotate to the other lever position. Make sure the cam returns to the full height position with the cam lever resting fully in the groove.

**NORMAL OPERATION**  
(vent on rising level)

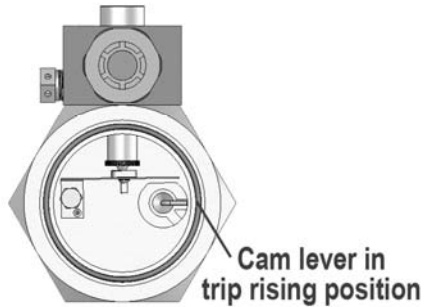

**ALTERNATE OPERATION**  
(vent on falling level)

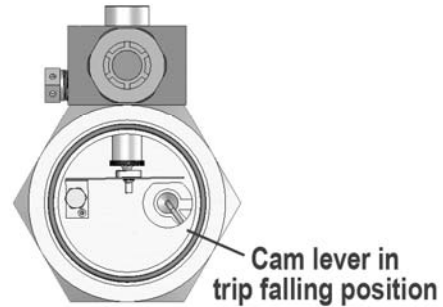

## Replacing and Installing the DVO Assembly

**NOTE:** When replacing/installing the DVO assembly, tubing and fitting modifications may be required. We suggest removing the LS200NDVO/DVOR from the vessel. Relieve pressure from the vessel or use block valves before removing the LS200NDVO/DVOR.

### Models LS200NDVO & LS200NDVOR

---

**NOTE:** Clean, dry instrument-quality gas should be used. Use and regular maintenance of filters will improve service life and reliability.

### Tools Needed

- Strap or pipe wrench
- 9/16" Hex wrench
- Tubing cutters and benders



**CAUTION:** LS200 series parts are not interchangeable with the L1200 Series.

## Instructions

1. Block off and bleed the instrument gas pressure supply to the LS200NDVO/DVOR.
2. Remove the tubing between the LS200NDVO/DVOR and the scrubber dump valve, and remove the supply gas tubing (regulator [-R-] if used).
3. Remove the LS200NDVO/DVOR from the vessel (optional).
4. If the LS200NDVO/DVOR was removed from the vessel, mount it in a suitable vise on a work bench (if possible).
5. Using the proper tools, disconnect the Inlet, Outlet, and Exhaust fittings from the existing DVO. See **Figure 1**. You will re-connect these to the new DVO in a later step.

**NOTE:** The following steps must be done with the DVO in the upright position (on top of the LS200NDVO).

6. Remove the LS200NDVO/DVOR cover. The use of a strap wrench or a pipe wrench may be needed.
7. With a 9/16" hex wrench, loosen the hex head bolt on top of the DVO and remove the existing DVO from the body.
8. Ensure that the adjustable orifice is fully raised up so that the actuator arm is not bent when inserted into the body. See **Figure 2**.
9. Insert the new DVO onto the body. The DVO manual valve operator must face away from the vessel. See **Figure 3**.

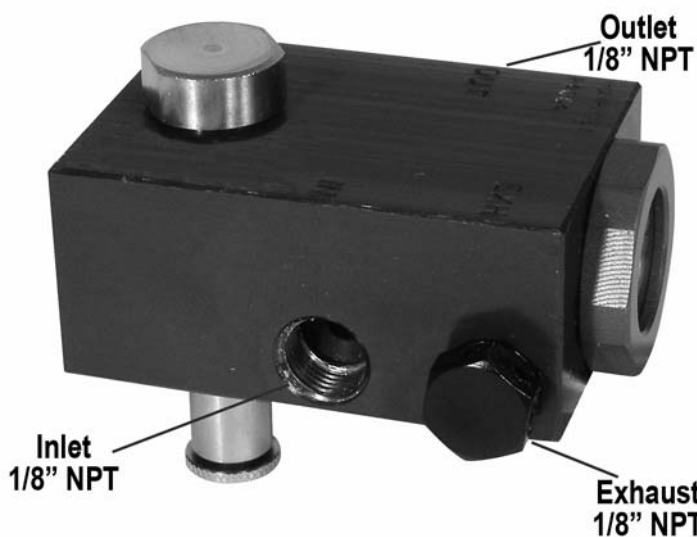

**Figure 1 - DVO**



**Figure 2 – Adjustable Orifice**



CAUTION: Ensure that the actuator arm is not bent during reassembly.

10. With the DVO aligned over the hex on the LS200NDVO body, tighten the valve using the 9/16" hex wrench. You may need to hold the DVO while tightening to keep it from rotating.
11. The pneumatic input signal should be regulated between 30 and 70 psi for proper setting of the adjustable orifice. With the float in the down position adjust the adjustable orifice down until it touches the seat. See **Figure 4**.

If the DVO is still leaking make slight adjustments (1/32 turn). Excessive adjustments will lock up mechanisms. After adjusting make sure float moves freely up and down.

12. Replace the LS200NDVO/DVOR cover.
13. Using the appropriate tools re-install the inlet, outlet, and exhaust fittings to the new DVO.

**NOTE:** Thread sealant is recommended although care should be used to not allow excess to enter valve.



**Figure 3 – DVO manual valve operator**

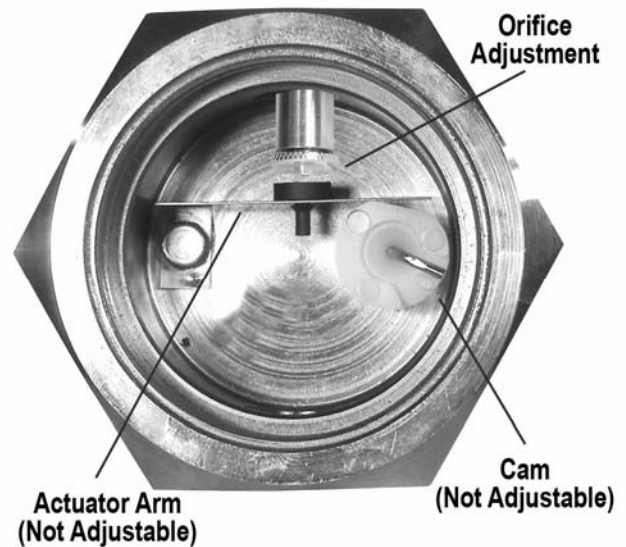
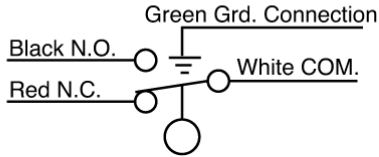

**Figure 4 – Orifice Adjustment with float in down position**

14. Connect to the inlet, outlet, and exhaust fittings according to installation drawings.

## Electrical

### SPDT (Snap Switch)



**Switch Rating:** 5 A @ 125-250- 480 VAC  
1/2 A @ 125 VDC  
1/4 A @ 250 VDC  
2A @ 6-30 VDC Resistive  
1A @ 6-30 VDC Inductive

### DPDT (Snap Switch)

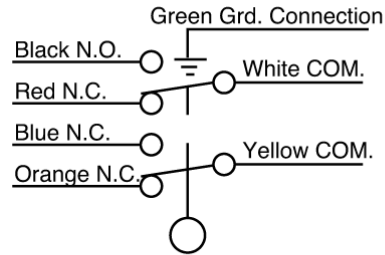

**Switch Rating:** 10 A @ 125-250 VAC  
1/2 A @ 125 VDC  
1/4 A @ 250 VDC  
10 A @ 6-24 VDC  
Inductive/Resistive

## Replacement Parts



CAUTION: LS200 Series parts are not interchangeable with other Murphy liquid level products. Damage caused by the above mentioned is not covered by our Limited Warranty.

Order by part number designation.

### LS200

15000479: Stainless Steel float for LS200 (not interchangeable with L1200)  
15000124: SPDT snap switch assembly  
15010268: LS200 counter balance assembly  
15000478: Float shaft extension (not interchangeable with L1200)

### LS200N

15000479: Stainless steel float for LS200N (not interchangeable with L1200)  
15051133: Valve stem

### LS200NDVO and LS200NDVOR

55050621: Regulator only  
05706499: 20BPG-D-75 Pressure MURPHYGAGE®  
0-75 psi (517 kPa) [5.17 bar]  
15010267: Assembly (**LS200N DVO Assembly**)

## L1100

- 15000893: BUOYGLAS™ float
- 15000937: Stainless steel float
- 15000124: SPDT snaps switch assembly
- 15000892: Float shaft extension

## Accessories

### 15050375: Weld Collar

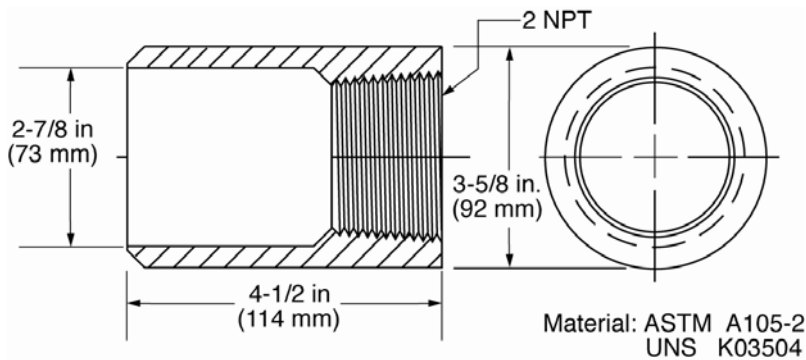

Operating Pressure: 2000 psi (13.8 MPa) [138 bar].

Operating Temperature: 400°F (204°C).

### 55050617: DVU150/DVU175 Adapter Bushing

Order by part number designation

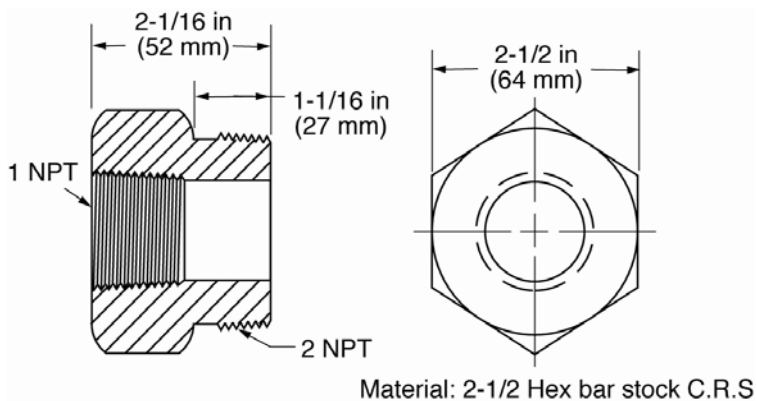



## 15051098: External Float Chamber

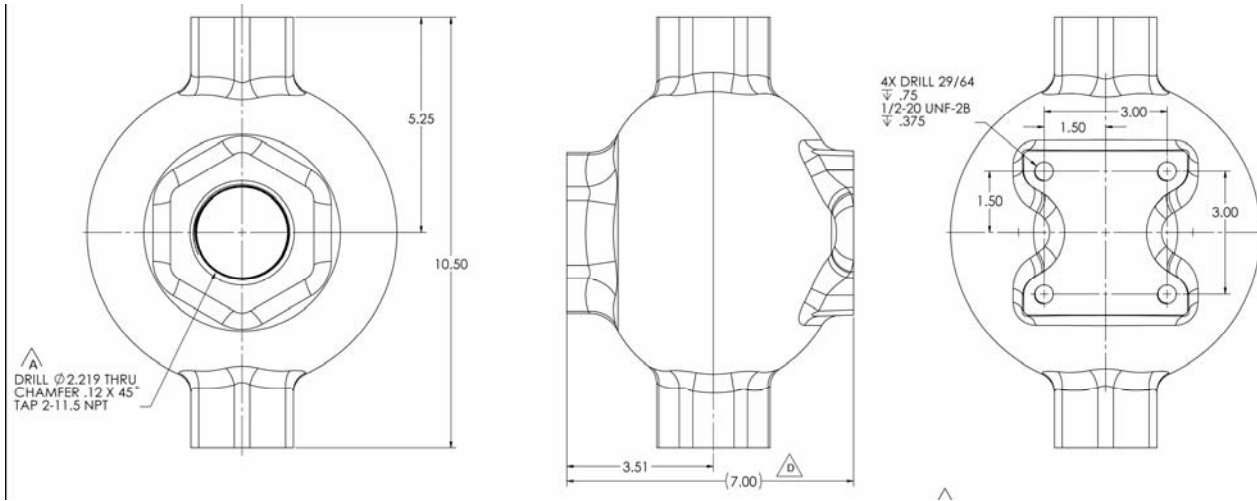

Operating pressure: 2000 psi (13.8 MPa) [138 bar]

Operating temperature: 400°F (204°C).

## 15700799: Series 100 External Float Chamber

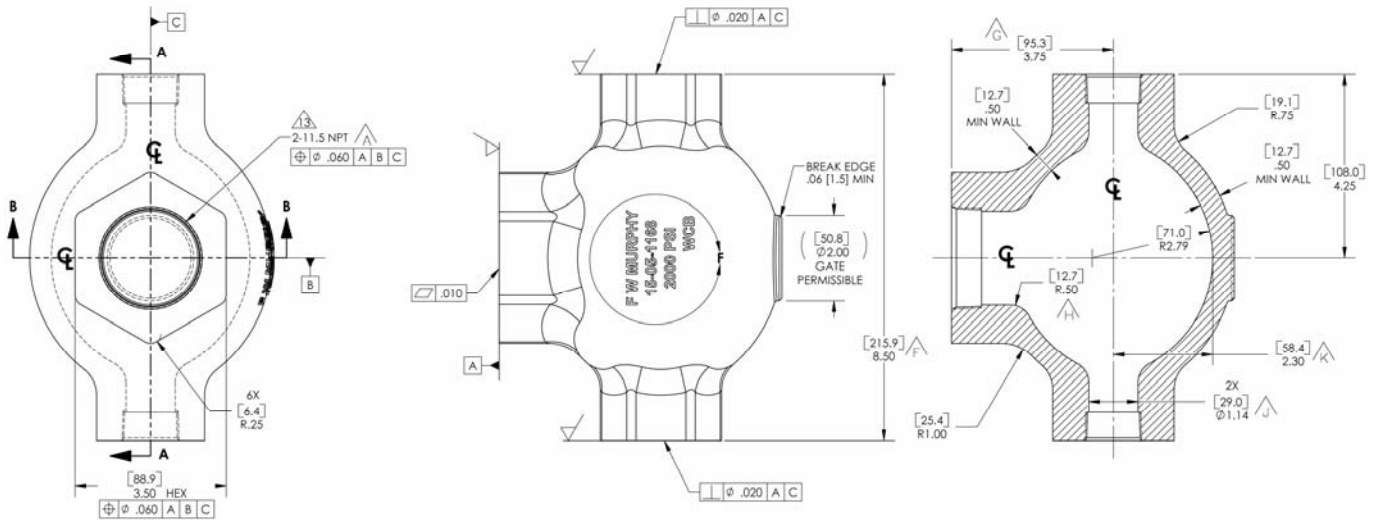

Operating pressure: 2000 psi (13.8 MPa) [138 bar]

Operating temperature: 400°F (204°C).

## 15000478: Float Shaft Extension for the LS200

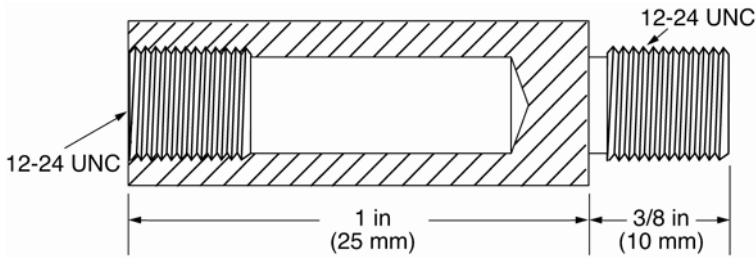

Material: AISI 303, UNS-S30300



CAUTION: Not interchangeable with L1200 parts.

Use of 1" extension requires additional clearance and will operate in .65 specific gravity and heavier. See 'Minimum Clearance Table' listed in the "Pressure Vessel Installation: LS200, LS200N and L100" chapter of this manual.

## 15000892: Float Shaft Extension for the L1100

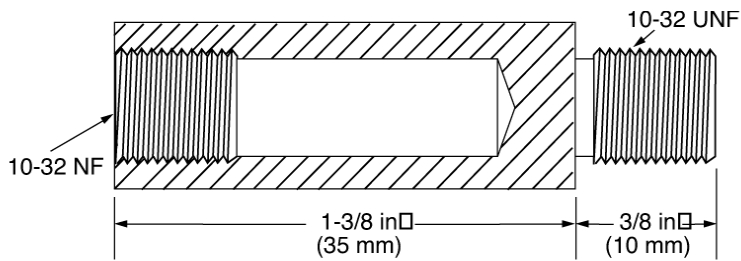

Material: AISI 304, UNS-S30400

# The Murphy Gas Compressor Scrubber Level System (SLS)

## The Murphy Gas Compressor Scrubber Level System (SLS)

The system provides for liquid control in gas scrubber applications, by dumping liquids to drain and protecting compressors with a high liquid level switch. Wetted metal parts are made to survive constant use in corrosive environments. See Bulletin: SLS-04005B for more details.

**Filter/Regulator & MURPHYGAGE**  
"Instrument Quality Air/Gas Supply"  
**Pneumatic Level Control**  
Float actuated level snap-acting switch controls pneumatic pressure to open and close dump valve.  
**LS200NDVOR:** Dump Valve Operator, pressure regulator, and pressure indicating MURPHYGAGE.

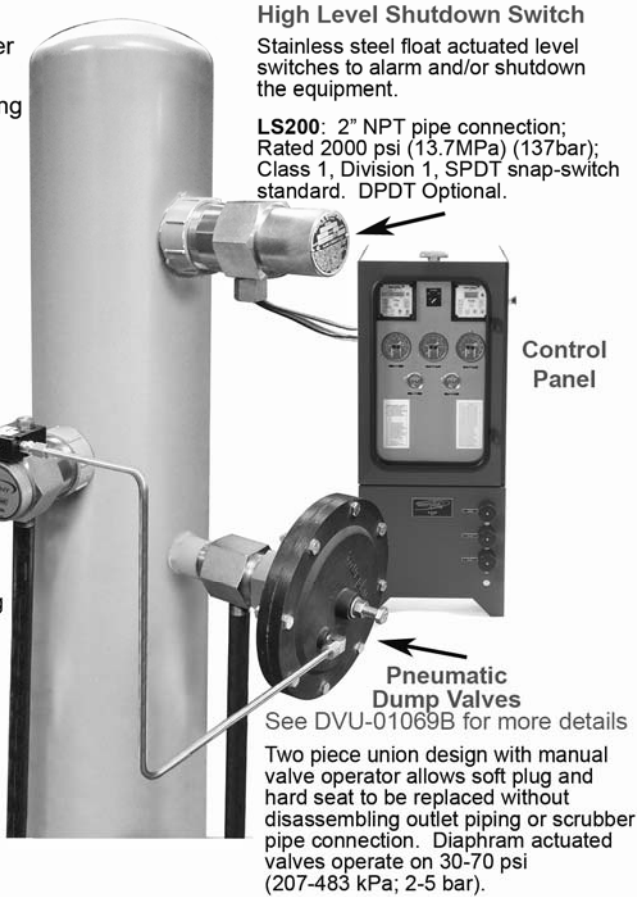

**High Level Shutdown Switch**  
Stainless steel float actuated level switches to alarm and/or shutdown the equipment.  
**LS200:** 2" NPT pipe connection; Rated 2000 psi (13.7MPa) (137bar); Class 1, Division 1, SPDT snap-switch standard. DPDT Optional.  
**Control Panel**  
**Pneumatic Dump Valves**  
See DVU-01069B for more details  
Two piece union design with manual valve operator allows soft plug and hard seat to be replaced without disassembling outlet piping or scrubber pipe connection. Diaphragm actuated valves operate on 30-70 psi (207-483 kPa; 2-5 bar).

# Specifications

## All Models

---

- Body: Nickel plated steel; optional 316 stainless steel (meets NACE standard MR-01-75 for direct exposure to H<sub>2</sub>S service)
- Float: 304 stainless steel to operate in 0.5 specific gravity or heavier fluids
- Pressure rating: 2000 psig (13.8 MPa) [138 bar] (LS200 models only)
- O-ring: Viton

## LS200

---

- Process connection: 2" NPT
- Temperature rating: -20 to 300°F (-29 to 149°C)
- Electrical: SPDT std. (see "Electrical" section for configuration/rating).
- Wiring: 18 AWG x 36 in. (1.0 mm<sup>2</sup> x 916 mm)

## LS200NDVOR

---

- Process connection: 2" NPT
- DVO valve: 3 way N.C. w/manual operator, all connections 1/8" NPT (minimum 30 psig required)
- Filter/pressure regulator set:
  - Regulator: 0 to 75 psig (0 to 517 kPa) [0 to 5.17 bar] range
  - Maximum input pressure: 300 psig (2.07 MPa) [20.7 bar]

## LS200NDVO

---

- Process connection: 2" NPT
- DVO valve: 3 way N.C. w/manual operator; all connections 1/8" NPT

## LS200 N

---

- Process connection: 2" NPT
- Vent valve: 2 way N.C. snap action w/ 1/16in. (2mm) orifice and Viton seat; Inlet: 1/8" NPT; outlet 3/8" NPT

## L1100

---

- Process connection: 1-1/2" NPT
- Pressure rating: 1500 psig (10.3 MPa) [103.2 bar]
- Float: BUOYGLAS™ operates to 0.5 specific gravity;  
Optional stainless steel to operate in 0.65 specific gravity
- Electrical: SPDT switch

## Approximate Shipping Weights and Dimensions

---

All models: 6 lb. 10 oz. (3 kg);  
14 x 5 x 3-1/2 in. (356 x 127 x 89 mm)

MURPHY, the Murphy logo, and Liquid level Switches (LS) are registered and/or common law trademarks of Murphy Industries, Inc. This document, including textual matter and illustrations, is copyright protected by Murphy Industries, Inc., with all rights reserved. (c) 2005 Murphy Industries, Inc. Other third party product or trade names referenced herein are the property of their respective owners and are used for identification purposes only.

**FW MURPHY**

P.O. Box 470248  
Tulsa, Oklahoma 74147 USA  
+1.918.317.4100 Fax: +1.918.317.4266  
E-mail: sales@fwmurphy.com

**INDUSTRIAL PANEL DIVISION**

Fax: 918.317.4124  
E-mail: ipdsales@fwmurphy.com

**MURPHY POWER IGNITION**

Web site: www.murphy-pi.com

**www.fwmurphy.com**

**CONTROL SYSTEMS & SERVICES DIVISION**

P.O. Box 1819  
Rosenberg, Texas 77471 USA  
Phone: 281.633.4500 Fax: 281.633.4588  
E-mail: sales@fwmurphy.com  
Web site: www.fwmurphy.com

**FRANK W. MURPHY, LTD**

Church Rd Laverstock  
Salisbury SP1 1QZ UK  
Phone: +44 1722 410055 Fax: +44 1722 410088  
E-mail: sales@fwmurphy.co.uk  
Web site: www.fwmurphy.co.uk

**COMPUTRONIC CONTROLS, LTD**

41 - 43 Railway Terrace Nechells  
Birmingham B7 5NG UK  
Phone: +44 121 327 8500 Fax: +44 121 327 8501  
E-mail: info@computroniccontrols.com  
Web site: www.computroniccontrols.com

**FW MURPHY INSTRUMENTS (HANGZHOU) CO. LTD**

77 23rd Street  
Hangzhou Economic & Technological Development Area  
Hangzhou, Zhejiang, 310018, China  
Phone: +86 571 8788 6060 Fax: +86 571 8684 8878



**ISO 9001**  
REGISTERED