

Crankcase Level Switch

L971 Series

The L971 Series Level Switch detects low oil level in a compressor's crankcase. As oil level in the crankcase depletes, the float on the L971 switch falls, and when reaching the predetermined limit, it will trip the internal snap-switch sounding an alarm or initiating shutdown. The L971 is designed for Ingersoll-Rand Type 30, Type 40 and ESH compressors, yet it can be adapted to fit other compressors that have an inspection plate extending below normal operating oil level. It installs with minimal downtime and has a two-year limited warranty.

The L971 has a 1/2 NPT process connection and features an explosion-proof enclosure, durable SPDT snap-switch and rigid polyurethane foam float. A 304 stainless steel float is available on certain configurations.

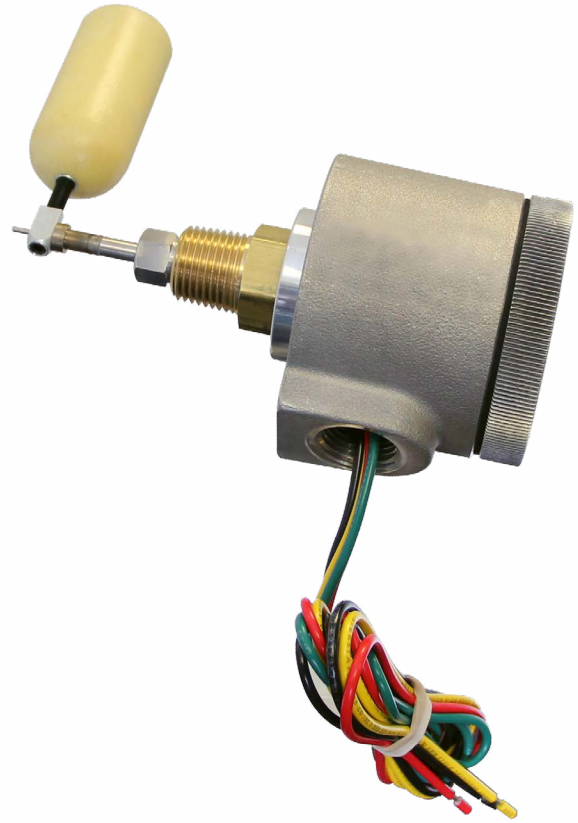

Specifications

Operating Temperature Range: -15 to 275° F (-26 to 135° C)

Maximum Working Pressure: 30 psi (206 kPa) [2.06 bar]

Switch Rating: 4 A @ 250 VAC

Case: Aluminum (explosion-proof)

Mounting Adaptor: Brass

Floats: Rigid polyurethane.

304 stainless steel available on L971-C only

Other Wetted Parts: 303, 304 and 316 stainless steel

O-Ring Seals: Viton and Buna

Process Connection: 1/2 NPT

Hazardous Location Rating:

UL and CSA listed for Class I, Groups C & D; Class II, Groups F & G

Enclosure Type / Ingress Protection Rating:

IP66 per IEC 60529.

Conduit Connection: 1/2 NPT

Wire: 18 AWG (0.75 mm²)

Shipping Weight: 1 lb. 10 oz. (0.7 kg)

Shipping Dimensions:

8-1/4 x 4-1/4 x 4-1/2 in. (210 x 108 x 114 mm)



* Products covered by this bulletin comply with EMC Council directive 89/336/EEC regarding electromagnetic compatibility except as noted.

All trademarks and service marks used in this document are the property of their respective owners. This Enovation Controls product is exclusively distributed by FW Murphy in the Natural Gas Compression Market.

Wiring

Diagram is shown in the shelf position with no force acting upon float.

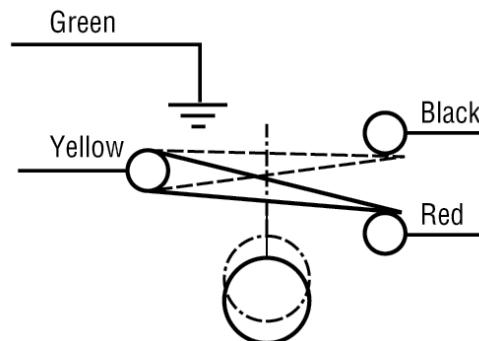

Dimensions

L971

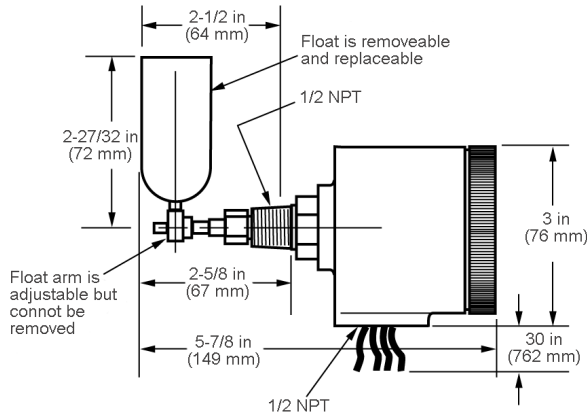

L971-C

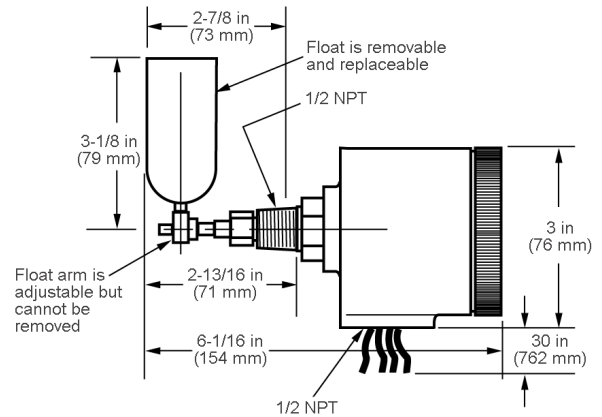

Case/Float Configuration Diagram

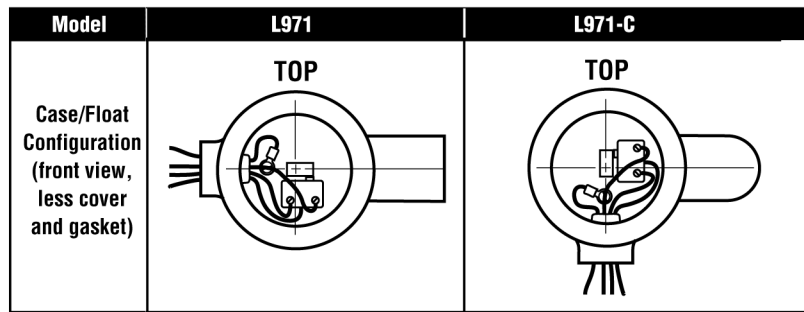

NOTE: Switches shown tripped on falling level.

How to Order

Options are ordered by Case/Float Configurations. Please reference the Case/Float Configuration Diagram and the Dimensions for each model. All configurations may not be available. Call your sales representative or FW Murphy for more information.

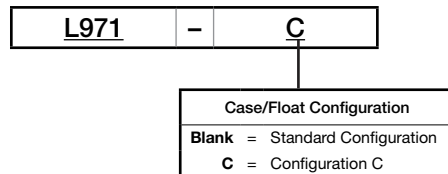

Approximate Shipping Weight and Dimensions		
Model	Weight	Dimension
L971 Series	1 lb. 10 oz.	8-1/4 x 4-1/4 x 4-1/2 in.