

Liquid Level Controllers

LC10 Series

The LC10 is a rugged, displacer-operated liquid level controller that is ideal for use on scrubbers, separators, heater treaters or anywhere else liquid level control is needed. Its industry-proven, force-balance design allows for control of gas/liquid as well as liquid/liquid interfaces.

The LC10 can be mounted on the left-or right-hand side and can be set up for direct or reverse acting. Both the mounting and action are field reversible. It's available with an easily replaceable snap or throttling pilot for pneumatic control. The snap pilot is available with a soft seat option that meets 40 CFR Part 60, Subpart 0000. SPDT and DPDT switches are available for electric control.

A wide variety of sizes and end connections are available as well as many different displacer arm lengths to fit any vessel configuration. A NACE option is also available for sour service.

Specifications

Sizes:

Threaded: 1 1/2" and 2"

Flanged: 2" to 8"

Union: 4" and 5"

Pressure Rating:

Threaded: 6000 psi

Flanged: Up to ANSI 2500 class

Union: 1500 psi

Temperature Range:

-50° F to 400° F (varies by material selections)

Pilot Connections:

1/4" NPT

Pilot Max Pressure:

Limited by gauges

Electric Switch Ratings:

SPDT: 15 A @ 125, 250, 480 VAC

DPDT: 10 A @ 125 VAC

Materials:

Body: A105, LF2 (low temp option), SST

Body Trim: 303 stainless and 316 stainless (optional)

Pilot Body: Aluminum

Pilot Trim: 303 stainless

Case: Aluminum

Case Internals: 303 stainless

Displacer: PVC (standard), acrylic, stainless

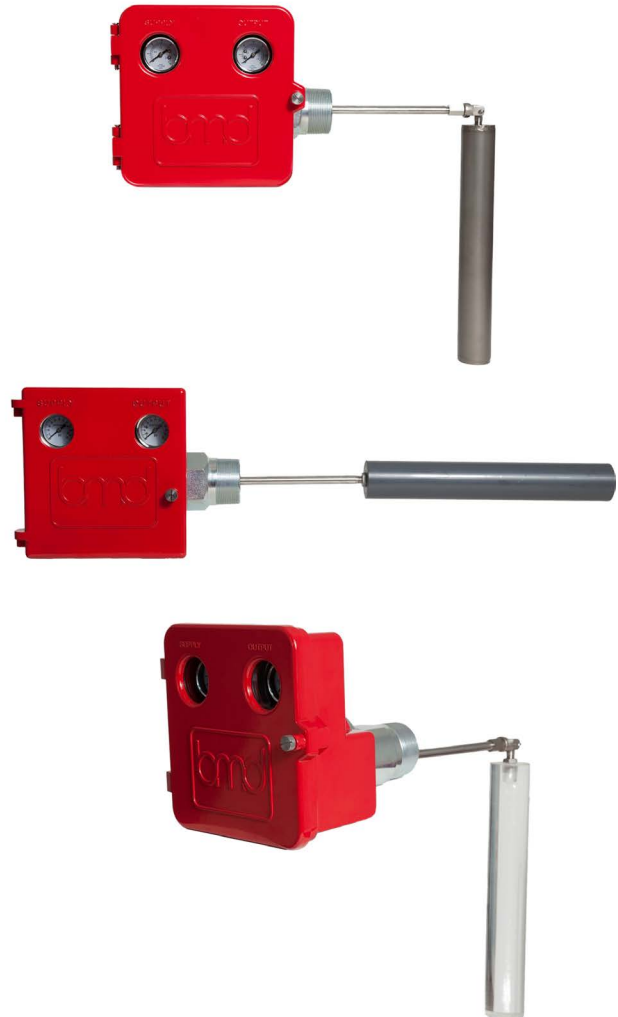

All trademarks and service marks used in this document are the property of their respective owners. This Beaumont Manufacturing and Distribution Co. product is exclusively distributed for new equipment packages by FW Murphy in the Natural Gas Compression market.

| Minimum Fluid Specific Gravities | | |
|----------------------------------|------------|----------------|
| Displacer Orientation | Snap Pilot | Throttle Pilot |
| Vertical | 0.21 | 0.42 |
| Horizontal | 0.28 | 0.56 |

| Temperature Limits for Displacer and Seal Combinations | | | | | | |
|--|------------|-----------|------------|-----------|-----------------|------------|
| Displacers | PVC | | Acrylic | | Stainless Steel | |
| | °F | °C | °F | °C | °F | °C |
| Buna | -20 to 140 | -29 to 60 | -20 to 180 | -29 to 82 | -20 to 225 | -29 to 107 |
| Low-Temp Buna | -50 to 140 | -46 to 60 | -50 to 180 | -46 to 82 | -50 to 225 | -46 to 107 |
| Viton® | -20 to 140 | -29 to 60 | -20 to 200 | -29 to 93 | -20 to 400 | -29 to 204 |

Dimensions

Inch (mm)

Left/Right Hand Mounted

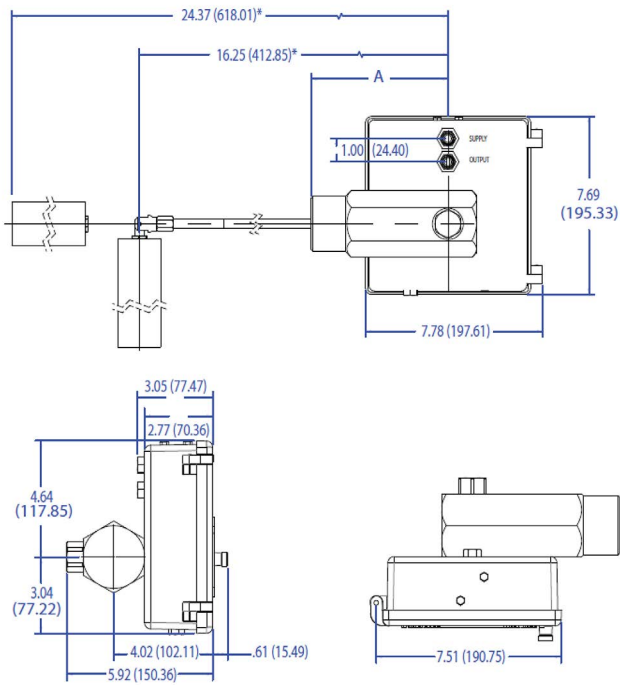

* Dimensions for standard sizes.

Back Mounted

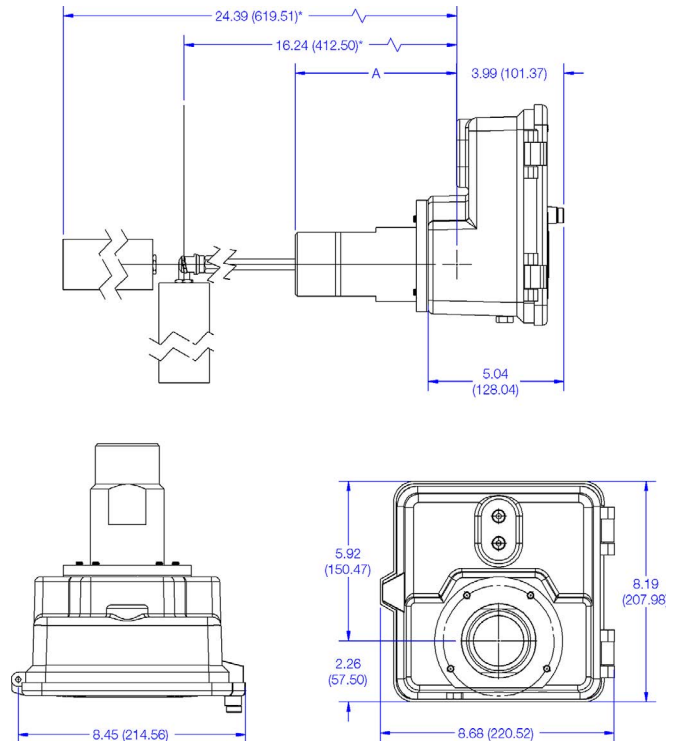

Sealed Case

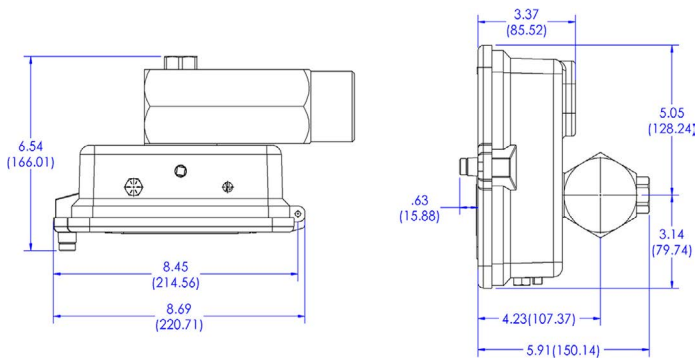

| Connection | Dimension A | | | | | | | |
|------------|-------------|-------|-------|--------|-------|--------|--------------------|-------|
| | 1.5" / 2" | | 3" | | 4" | | 6" | |
| | In. | mm | In. | mm | In. | mm | In. | mm |
| NPT | 6.00 | 152.4 | N/A | N/A | N/A | N/A | N/A | N/A |
| Butt Weld | 6.00 | 152.4 | N/A | N/A | N/A | N/A | N/A | N/A |
| 150# RFF | 6.50 | 165.1 | 6.56 | 166.62 | 6.56 | 166.62 | 6.50 | 165.1 |
| 300# RFF | 6.81 | 173.0 | 6.75 | 171.45 | 6.88 | 174.75 | 6.94 | 176.3 |
| 600# RFF | 7.19 | 182.6 | 7.12 | 180.85 | 7.50 | 190.50 | 11.00 | 279.4 |
| 600# RTJ | 7.25 | 184.2 | 7.31 | 185.67 | 7.56 | 192.02 | 11.00 | 279.4 |
| 900# RFF | 8.00 | 203.2 | 9.63 | 244.60 | 10.13 | 257.30 | Consult Factory | |
| 900# RTJ | 8.06 | 204.7 | 9.69 | 246.13 | 10.19 | 258.83 | | |
| 1500# RFF | 8.00 | 203.2 | 10.25 | 260.35 | 10.63 | 270.00 | | |
| 1500# RTJ | 8.06 | 204.7 | 10.31 | 261.87 | 10.69 | 271.53 | | |
| 2500# RFF | 8.50 | 215.9 | 11.06 | 280.92 | 11.75 | 298.45 | | |
| 2500# RTJ | 8.56 | 217.4 | 11.13 | 282.70 | 11.81 | 299.97 | | |

8" - Consult Factory

Typical Mounting

Left-Hand Mount

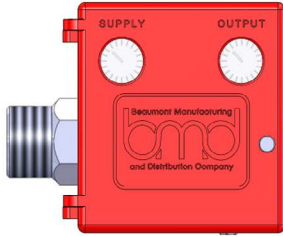

Right-Hand Mount

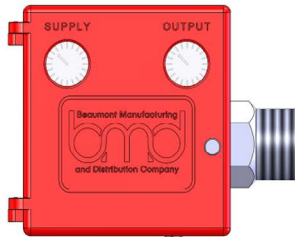

How to Order

You can customize your Level Controller by using the part numbering system detailed below. Please refer to the tables for dimensions and specifics. Repair kits available.

Example Model No. **LC10-2N50R-1B-01PV15-P1**

LC10 Series Level Controller, 2" NPT Connection, Right-Hand Direct, Carbon Steel Body, 303 Trim, Buna Seals, 1.88 x 12" PVC Displacer, Vertical, 15" Arm, Snap Pilot, 0-30 Brass Gauges

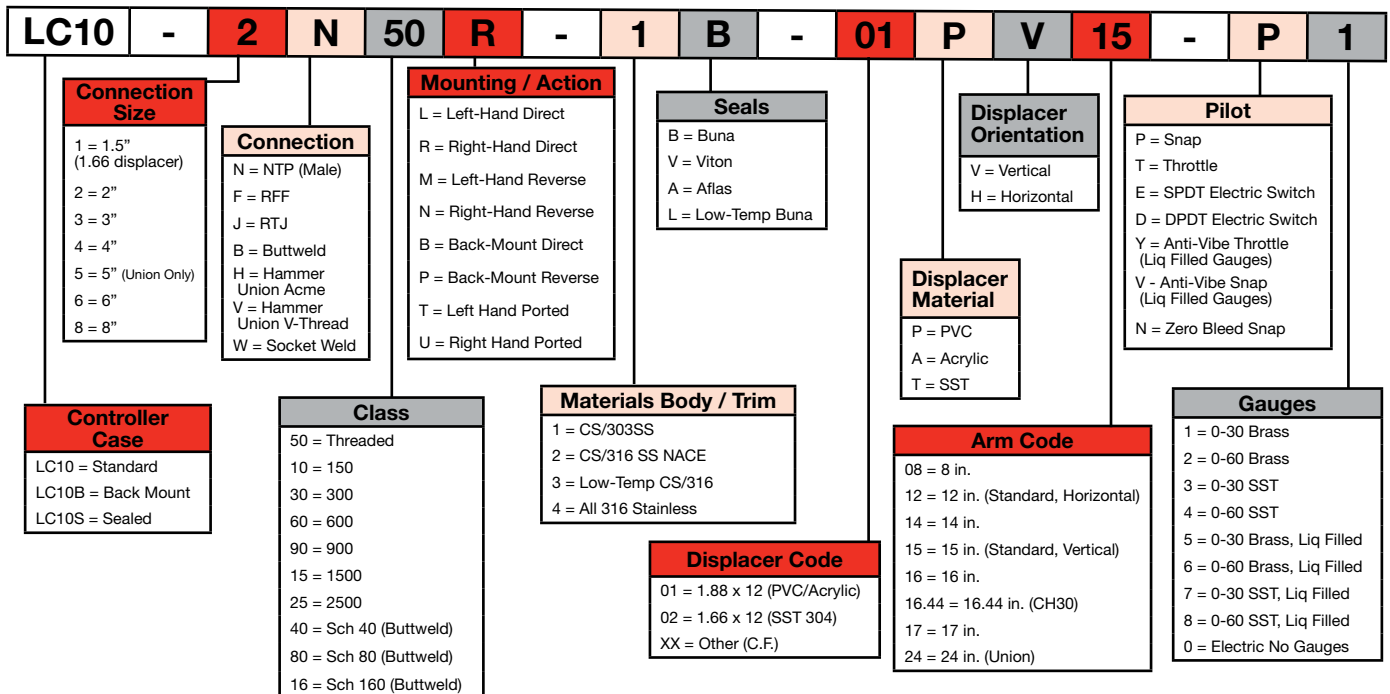

FW Murphy is the exclusive BMD distributor for new equipment packages.

This Page Has Intentionally Been Left Blank