

Gauge Valves

GV20 Models

The GV20 Gauge Valves are designed to be used with BMD's LG20 Level Gauges but also are compatible with all armored flat-glass level gauges.

Union tank connections make for easy installation and removal.

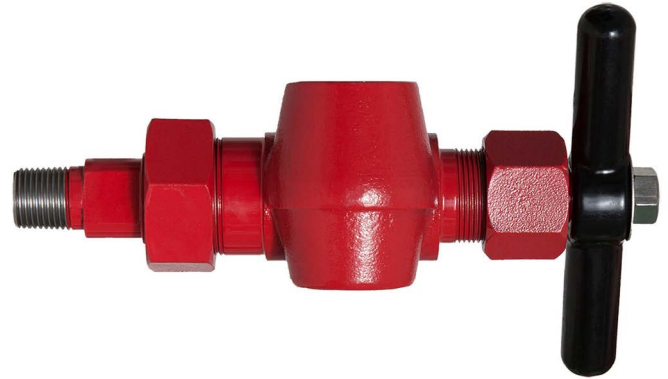

All trademarks and service marks used in this document are the property of their respective owners. This Beaumont Manufacturing and Distribution Co. product is exclusively distributed for new equipment packages by FW Murphy in the Natural Gas Compression market.

Specifications

Connections:

Sight Glass Connection: 1/2" FNPT

Tank Connection: 1/2" and 3/4" union

Features

Safety Shutoff: SST ball check upstream of the seat shuts off medium flow in the event of glass breakage

Ergonomic Handle: Sturdy 0.75" diameter tee handle for ease of use and comfortable operation

Offset Design: Body and drain connections are offset from the tank connection for easy glass cleaning

NACE Compatible: Wetted parts conform to NACE MR-01-75 specifications for sour gas service

Dimensions

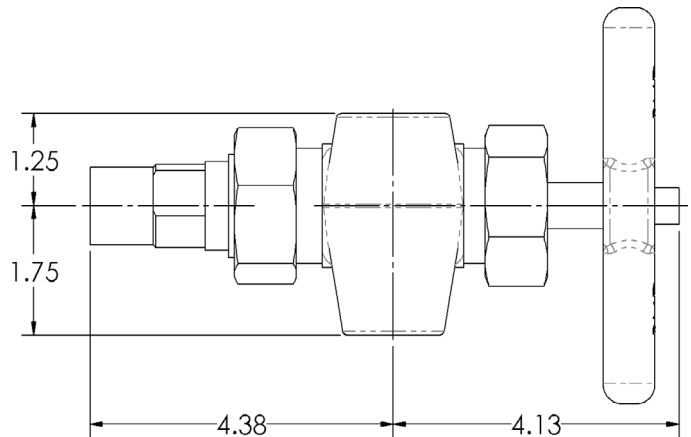

How to Order

Options are listed below. All configurations may not be available. Call your sales representative or FW Murphy for more information.

Example Model No. **GV20-F1**

GV20 Gauge Valve with 1/2" Tank Union and 1/2" FNPT Glass Connections

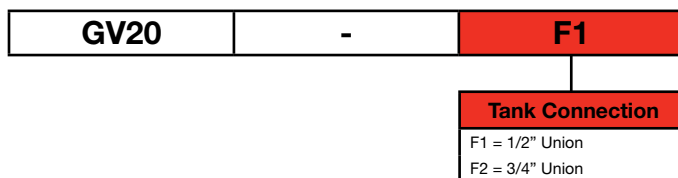

FW Murphy is the exclusive BMD distributor for new equipment packages.

This Page Has Intentionally Been Left Blank