

BGT and UT Series TANKTEND™ Systems

Installation and Operation Instructions

Models: BGT1, BGT1VR, UT1, and UT1VR

TNK-95049N
 Revised 02-97
 Section 15
 (00-02-0222)



Please read the following information before installing. A visual inspection of this product for damage during shipping is recommended before mounting. It is your responsibility to have a qualified person install this unit and make sure it conforms to NEC and local codes.

GENERAL INFORMATION

WARNING

BEFORE BEGINNING INSTALLATION OF THIS MURPHY PRODUCT

- ✓ Disconnect all electrical power to the machine.
- ✓ Make sure the machine cannot operate during installation.
- ✓ Follow all safety warnings of the machine manufacturer.
- ✓ Read and follow all installation instructions.

Description

The Murphy TANKTEND™ Series models BGT1, for single, above ground tanks, and UT1 for single, remote monitoring below ground tanks can meet most single tank remote inventory monitoring requirements.

All of the Murphy BGT1 and UT1 TANKTEND™ systems are available with vapor recovery option (BGT1VR and UT1VR), which will compensate for gas blankets or head pressure caused by vapor recovery storage systems.

Specifications

BGT1 and BGT1VR Models

- Dial:** White dial with green and black markings, 4-1/2 in. (114 mm) diameter.
- Case:** Die cast aluminum, painted.
- Sensing Element:** Brass bellows actuated for greater accuracy; BGT1VR models feature a second set of bellows for vapor recovery monitoring.
- Lens:** Optically clear polycarbonate.
- Sensing Connection:** 1/4 NPTF; BGT1VR models include a second connection for vapor recovery monitoring, 1/8 NPTF.
- Shipping Weight:** 6 lbs. (2.72 kg).
- Shipping Dimensions:** 10 x 9 x 6 in. (254 x 229 x 153 mm).

UT1 and UT1VR Models

- Enclosure:** Cold rolled steel, weatherproofed (painted).
- Gaging System:** BGT1 or BGT1VR (specifications as above).
- Shipping Weight:** 26 lbs. (11.79 kg).
- Shipping Dimensions:** 16 x 16 x 10 in. (406 x 406 x 254 mm).

BGT1 and BGT1VR Dimensions

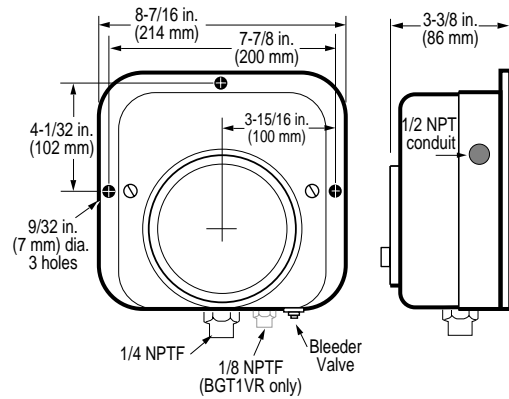

UT1 and UT1VR Dimensions

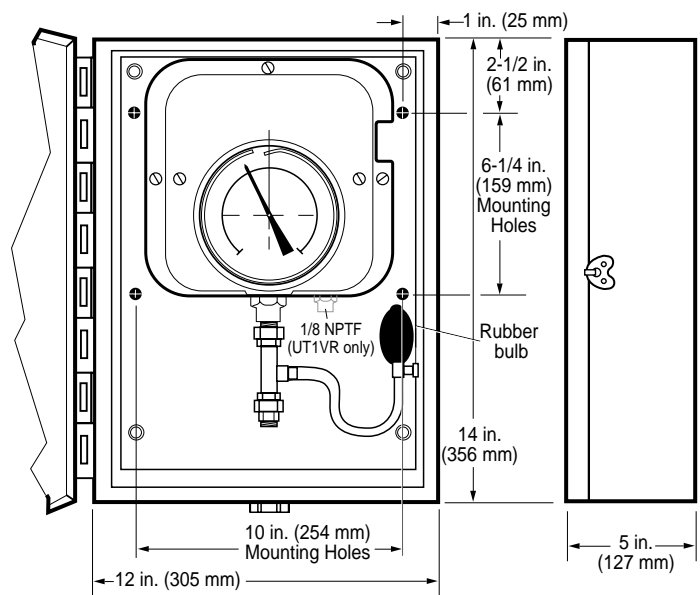

UTKN Tank Plug Kit (optional)

Includes: Either 2 NPTM or 4 NPTM tank plug; 304 stainless steel tubing 1/4 in. (6 mm) dia., 12 ft. (3.6 m) long; and fittings.

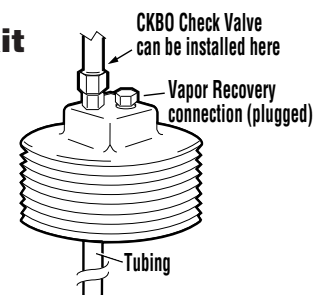

MOUNTING and INSTALLATION



WARNING: MOUNTING/INSTALLATION OF THE BGT1 AND UT1 SERIES MODELS MUST BE MADE BY QUALIFIED PERSONNEL ONLY. HAZARDOUS CONDITIONS EXIST WITH FLAMMABLE/CORROSIVE PRODUCTS, THEREFORE, ALL SMOKING MATERIALS MUST BE EXTINGUISHED. RISK OF EXPLOSION/FIRE AND BURNING CAN CAUSE SERIOUS OR FATAL INJURY.

Mounting

Mounting location should provide unobstructed view of the gage and unobstructed access. Before mounting the unit determine routing of the tubing (stainless steel tubing or rigid conduit) that connects the gage to the tank.

BGT1 and BGT1VR (For mounting dimensions see page 1.)

The BGT1 is designed to be mounted on a wall. The type of wall onto which the BGT1 case is to be mounted will determine the mounting hardware to be used. The illustration at right pictures the BGT1 mounted directly to the tank wall using a support bracket. We recommend that this or a similar type of bracket be used to avoid accidentally breaking the BGT1 from its fitting(s). Support bracket and hardware are supplied by the customer.

UT1 and UT1VR (For mounting dimensions see page 1.)

The UT1 weatherproof enclosure is designed to be mounted on indoor or outdoor walls away from the tank. Mounting can be in the control room or cashier station. Each unit is supplied with a length of tubing sensing line. Route the tubing line through rigid conduit or use stainless steel tubing to prevent damage.

The type of wall onto which the UT1 enclosure is to be mounted will determine the type of mounting hardware to be used.

Installing the BGT1 and BGT1VR

There are several accepted methods for installing the gage to above ground tanks. However, we recommend that actual installation procedures be determined by a qualified tank service company. Local codes and practices will dictate the proper installation for your area. Typical installation diagrams are illustrated at right.

1. The **Detail** (right) shows how to connect the gage directly into tank fitting. Use of sealant on all fitting threads is strongly suggested. Also, install a manual shut-off (2-way) valve between the gage and the tank connection, to facilitate instrument repairs or replacement. Keep plumbing parallel to tank bottom to avoid air traps. Make sure all connections are air tight.

Detail

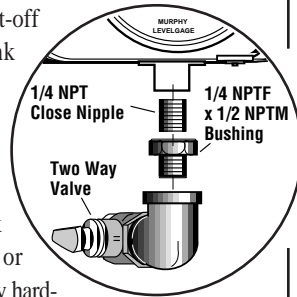

2. For BGT1VR models, tap into top of the tank and install a 1/4 NPT thermocouple fitting or install a Murphy UTKN tank plug kit. Necessary hardware is available from Murphy. See "Service Parts and Accessories" on page 4.
3. Install a sensing line from the BGT1VR second fitting (1/8 NPTF) to the UTKN tank plug or thermocouple fitting at top of the tank. Refer to BGT1VR Typical Installation drawing, shown at right, for reference.
4. The open end of the sensing line is to be installed through tank top and into the tank. Keep open end of the second sensing line above product level.
5. After the BGT1 / BGT1VR has been installed, air bleed the system, determine the actual level of product by reliable means such as stick/tape mea-

Mounting Bracket Installation

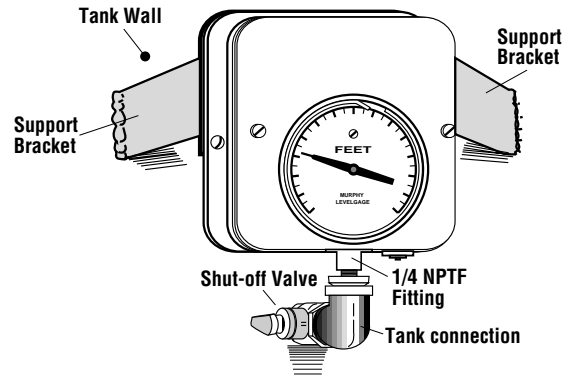

sure methods and reset the pointer for proper level indication (see page 4).

BGT1 Models Typical Installation

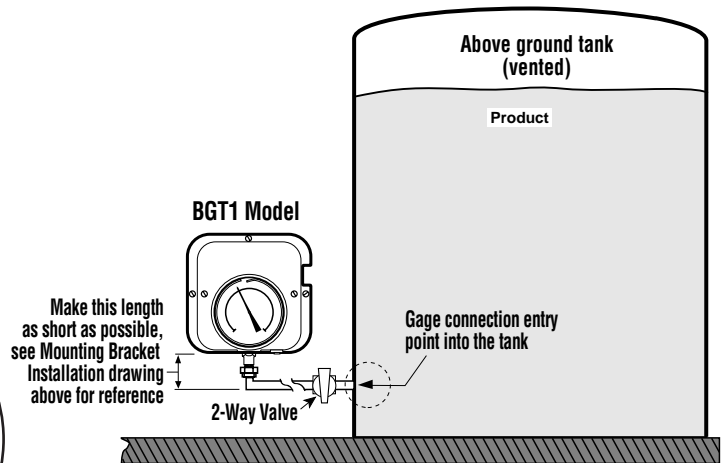

BGT1VR Typical Installation

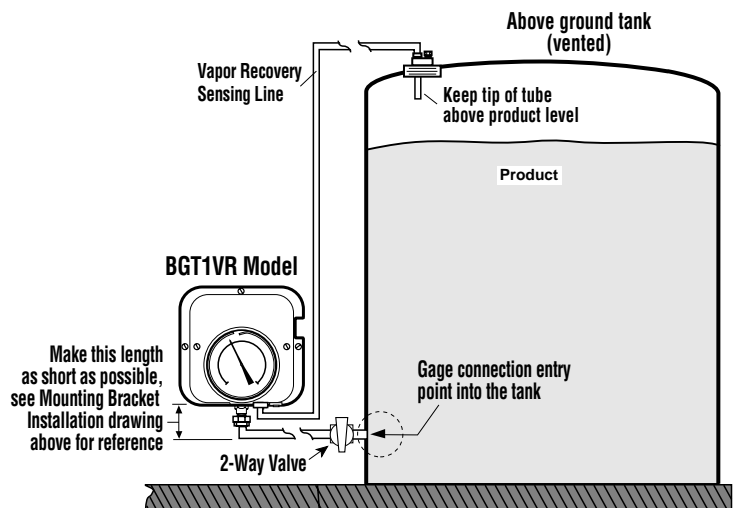

CAUTION: THE BGT1 AND BGT1VR ARE PRECALIBRATED IN FEET OF STATIC HEAD PRESSURE ABOVE THE GAGE CONNECTION TO THE TANK. THIS MEANS THE GAGE WILL NOT INDICATE ANY LEVEL BELOW GAGE CONNECTION ENTRY POINT INTO TANK. EXAMPLE: GAGE CONNECTED 2 FEET (609 MM) FROM BOTTOM; READING WILL NEVER DROP BELOW 2 FT. EVEN IF TANK IS EMPTY.

Installing the UT1 and UT1VR

NOTE: To install the UT1 and UT1VR a qualified tank service company should perform the installation to local codes and regulations.

1. Locate tank service cover and install UTKN tank plug kit. Necessary hardware is available from Murphy—see “Service Parts and Accessories” section, on page 4.
2. From tank top to gage panel location, either route through conduit or cut a channel in the driveway surface (if applicable) to run the tubing/line. Stainless steel tubing or rigid conduit is recommended when routing tubing under a driveway surface. The UT1 and UT1VR models include a length of tubing sensing line and fittings.
3. Before inserting the stainless steel tubing (probe) through tank plug fitting, make sure tubing can reach bottom and will allow extra tubing for adjustments.
4. Loosen compression nut and ferrule on tank plug. Insert stainless steel tubing (probe) through the compression nut, ferrule, tank plug fitting, and tank plug (see detail above).
5. Lower the stainless steel tubing (probe) until it touches tank bottom. Mark tubing at top of fitting—raise tubing exactly 3 in. (76 mm) off bottom of the tank and finger tighten ferrule and compression nut.

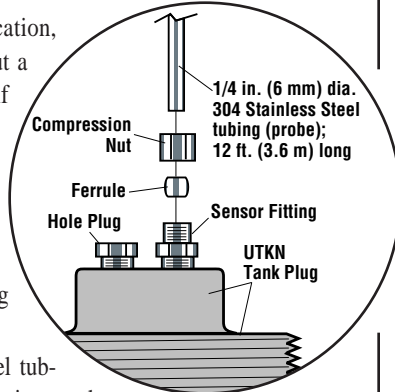

CAUTION: EXCESSIVE TIGHTENING OF FERRULE FITTINGS WILL PROHIBIT RE-ADJUSTMENT IF NECESSARY.

6. Cut excess stainless steel tubing (probe) allowing 1/2 in. (13 mm) extension above the compression nut.
7. Connect the tubing/sensing line to tank probe as shown (detail, at right).
8. Now connect other end of tubing line to the UT1 /UT1VR gage panel fitting. Tubing should be continuous length, without splices.
9. For UT1VR models, connect a second line from the tank top (if using UTKN kit, remove Hole Plug and install second sensor fitting and line) to the UT1VR gage 1/8 NPTF fitting line. Second sensing line is to be installed through the tank top and into the tank, but keep the tip of the line above product level (see UT1VR Typical Installation drawing, shown at right).
10. Securely tighten all fittings. All connections must be air tight. After the UT1 / UT1VR has been connected, air purge the system and reset the pointer for proper level indication (see page 4).

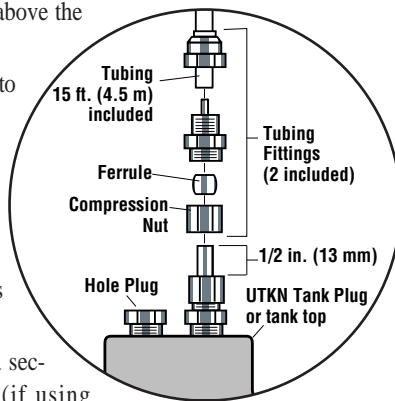

CAUTION: UT1 AND UT1VR MODELS ARE PRECALIBRATED IN FEET OF STATIC HEAD PRESSURE ABOVE GAGE CONNECTION. POINTER MUST BE RESET TO ZERO. SEE RESETTING THE POINTER ON P-4.

UT1 Models Typical Installation

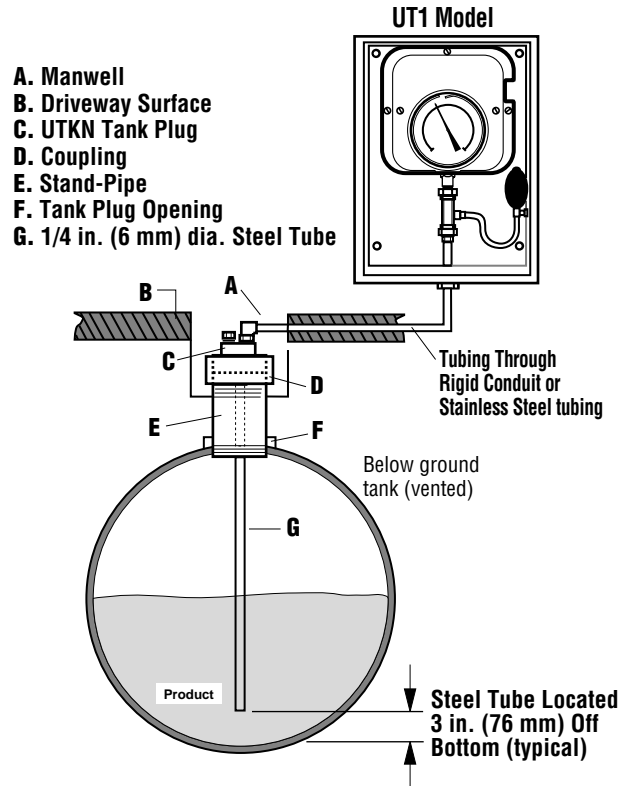

UT1VR Typical Installation

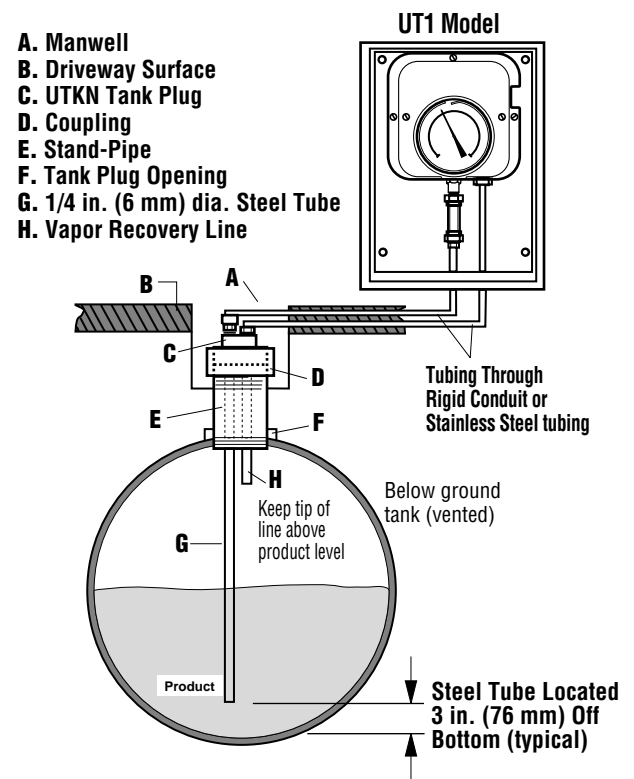

Connecting a CKBO Check Valve

The CKBO check valve is designed to prevent product from backing up into the gage. Install the CKBO valve at top of the tank plug as follows:

1. Determine the location for the valve. Use of sealant on all fitting threads is strongly suggested.
2. Attach CKBO to the tank plug using wrench on valve flats. See markings on valve body for positioning.
3. Attach tubing to CKBO as shown. Securely tighten all fittings. All connections must be air tight.

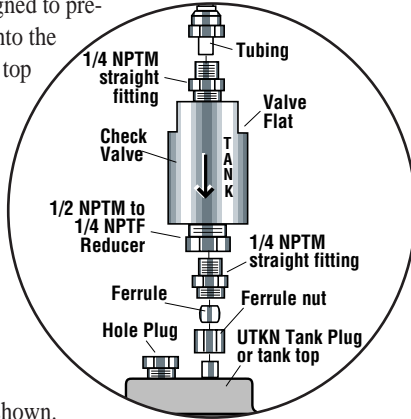

Resetting the Pointer

1. Determine the actual product level by reliable means such as the Stick or Tape measuring methods and record this value.
2. Open the gage case hinged cover by removing the two cover screws (see detail at right).
3. Carefully hold the pointer, as shown below, making sure not to bend it.
4. With a small screwdriver, turn the setting screw to corresponding stick reading value recorded in step 1. Clockwise to raise the pointer — counter clockwise to lower the pointer.
5. Close the hinged cover and replace the two screws.

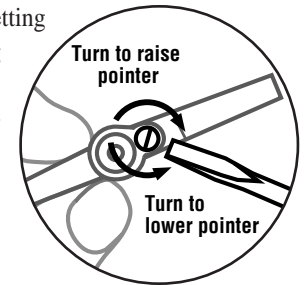
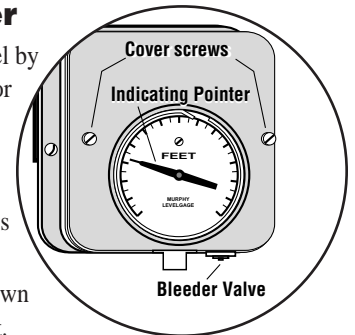

Bleeding Air Out of BGT1 and BGT1VR

To air bleed your gage proceed as follows:

! IMPORTANT: BLEED ALL AIR OUT OF GAGE AFTER FIRST INSTALLATION OR IF TANK LEVEL DROPS BELOW GAGE ENTRY POINT INTO TANK; OTHERWISE GAGE ACCURACY WILL BE AFFECTED.

1. First, make sure that the level of product in tank is above the gage.
2. Locate the bleeder valve (see gage drawing, at right).
3. Depress the bleeder valve and hold open until a solid stream of product flows out of the bleeder. The use of protective attire, gloves, goggles and a catch basin are recommended.
4. After air bleeding the gage, go to Resetting the Pointer, at right.

Purging the Sensing Line (UT1 and UT1VR)

Before resetting the pointer you must air purge your system as follows:

1. Open the UT1 enclosure hinged cover/door.
2. Squeeze the rubber bulb until the line is air purged and indicator pointer falters and can rise no further (this operation may take multiple squeezes).
3. Release the rubber bulb allowing the pointer to settle. Now go to Resetting the Pointer section, at right. Also remember, the system must be air purged every time you wish to read the tank level.

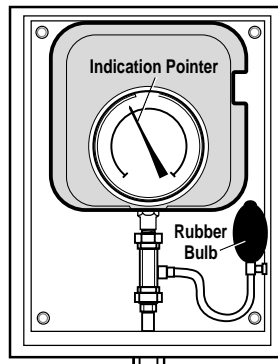

Service Parts and Accessories

- UTKN2:** 2 NPTM tank plug kit (includes 12 ft. [3.66 m] of stainless steel tubing/probe and fittings).
- UTKN2LT:** 2 NPTM tank plug less tubing (includes fittings).
- UTKN4:** 4 NPTM tank plug kit (includes 12 ft. [3.66 m] of stainless steel tubing/probe and fittings).
- UTKN4LT:** 4 NPTM tank plug less tubing (includes fittings).
- UTKN4VR:** 4 NPTM tank kit for vapor recovery (tubing and fittings included).
- UTKN4VRLT:** 4 NPTM tank plug for vapor recovery— less tubing (includes fittings).
- CKBO:** Check Valve assembly—prevents product from backing up into gage.
- UTSB:** Rubber bulb kit (squeeze bulb for UT1/UT1VR models).
- 86-02-0407:** 1/4 NPTM close nipple for gage direct mounting.
- 85-01-0405:** 1/2 NPTM x 1/4 NPTF reducing bushing—for BGT1/BGT1-VR direct mounting or CKBO valve.
- 85-01-0402:** 1/4 in. (6 mm) dia. 316 stainless steel tubing/Ft. (probe).
- 85-01-0403:** 1/4 in. (6 mm) dia. poly tubing/Ft. (sensing line).
- 86-03-0405:** 1/4 x 1/4 male hex nipple kit—for connecting poly tubing line to tank top.
- 85-03-0407:** 1/4 x 1/4 male hex fitting kit—for connecting poly tubing or probe line to the tank top.

Warranty

A two-year limited warranty on materials and workmanship is provided with this Murphy product. Details are available on request and are packed with each unit.

In order to consistently bring you the highest quality, full featured products, we reserve the right to change our specifications and designs at any time.



Frank W. Murphy Manufacturer
P.O. Box 470248; Tulsa, Oklahoma 74147; USA
tel. (918) 627-3550 fax (918) 664-6146
e-mail fwmurphy@ionet.net

Frank W. Murphy Southern Division
P.O. Box 1819; Rosenberg, Texas 77471; USA
tel. (281) 342-0297 fax (281) 341-6006
e-mail murphysd@intertex.net

Frank W. Murphy, Ltd.
Church Rd.; Laverstock, Salisbury SP1 1QZ; U.K.
tel. +44 1722 410055 fax +44 1722 410088 tlx 477088
e-mail sales@fwmurphy.co.uk

Frank W. Murphy Pte., Ltd.
26 Siglap Drive; Republic of Singapore 456153
tel. +65 241-3166 fax +65 241-8382
e-mail fwmsales@fwmurphy.com.sg

Murphok Pty., Ltd.
1620 Hume Highway; Campbellfield, Vic 3061; Australia
tel. +61 3 9358-5555 fax +61 3 9358-5558

Murphy de México, S.A. de C.V.
Bldv. Antonio Rocha Cordero 300, Fracción del Aguaje
San Luis Potosí, S.L.P.; México 78384
tel. +52-48-206264 fax +52-48-206336
e-mail murmexsl@sanluis.podernet.com.mx

Murphy Switch of California
P.O. Box 900788; Palmdale, California 93590; USA
tel. (805) 272-4700 fax (805) 947-7570
e-mail sales@murphyswitch.com

Frank W. Murphy France
tel. +33 1 30 762626 fax +33 1 30 763989