

SELECTRONIC® Digital Tachometer/TACHSWICH™ Installation Instructions

DT-8605N
Revised 07-97
Section 20
(00-02-0180)



DT9800 Series

Please read the following information before installing. A visual inspection of this product for damage during shipping is recommended before mounting. It is your responsibility to have a qualified person install this unit and make sure installation conforms to NEC and local codes.

GENERAL INFORMATION

WARNING

BEFORE BEGINNING INSTALLATION OF THIS MURPHY PRODUCT

- ✓ Disconnect all electrical power to the machine.
- ✓ Make sure the machine cannot operate during installation.
- ✓ Follow all safety warnings of the machine manufacturer.
- ✓ Read and follow all installation instructions.



**Factory
Mutual
System**

**Class I,
Division 2,
Group D**

Description

The Digital SELECTRONIC® DT9800 series features a tachometer-only and tachometer with built-in overspeed switch. These tachometers are highly accurate and dependable due to digital solid-state electronics and a quartz crystal time base. The surface-mount enclosure makes it easy to install. Tachometer power and RPM data are supplied by a magnetic pickup or capacitor discharge (CD) ignition—depending on model chosen. The RPM data is converted and displayed on a four digit, easy-to-read liquid crystal display (LCD). The LCD displays up to 9999 RPM.

The DT9803 and DT9804 are tachometer-only models. The DT9803 is powered by a magnetic pickup. The DT9804 is powered by a CD ignition.

The TACHSWICH™ models, DT9805 and DT9806, combine a digital tachometer and overspeed switch. The DT9805 is powered by a magnetic pickup and the DT9806 is powered by a CD ignition.

Specifications

Input Signal Source

DT9803: 18 to 112 volts peak to peak or 3.5 to 40 Vrms.

DT9805: 18 to 112 volts peak to peak or 7 to 40 Vrms.

DT9804 and DT9806: 90 to 400 VDC, CD ignition.

Temperature Range: -4 to 158°F (-20 to 70°C).

Accuracy: ±1 RPM.

Frequency Range:

DT9803 and DT9805: 1 to 15 KHz.

DT9804 and DT9806: 3 to 666 Hz.

Overspeed Switch Rating (DT9805 and DT9806 only):

SCR output. 5 A @ 400 VDC.

* Class I, Div. 2, Group D Hazardous Locations. Models DT9803 and DT9805 magnetic pickup powered 18 to 112 Vpp input. Models DT9804 and DT9806 used with CD ignition. Contact Murphy for details. The equipment must be installed in a suitable enclosure accepted by local authorities.

MOUNTING

- Before installing, be sure there will be enough clearance to access the calibration rocker switches and overspeed switches from the back of the panel.
- Drill mounting holes according to the dimensions below.
- Be sure the gasket is in place on the back of the tachometer before installing. Insert the tachometer from the front of the panel aligning the mounting studs with the appropriate holes. Secure the tachometer using the four 6/32 nuts, but do not overtighten the nuts as case damage could occur.

Mounting Hole Dimensions

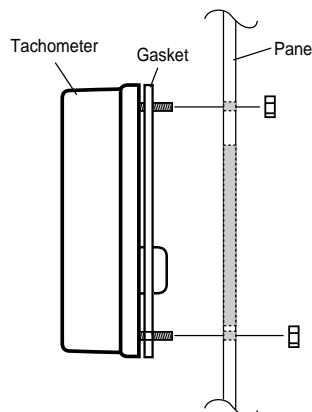
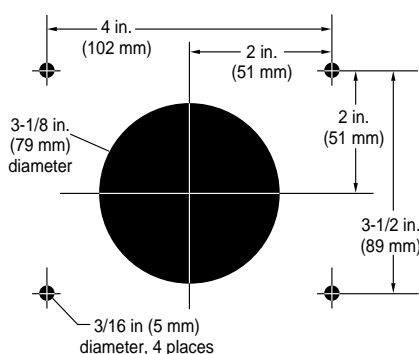

Back View

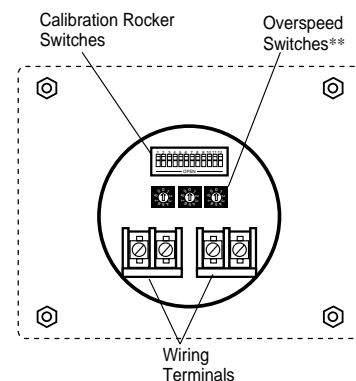

**Applies to overspeed models only.

DT9803 AND DT9804 TYPICAL WIRING



WARNING: PERFORM THE WIRING INSTALLATION WITH THE POWER SOURCE OFF. DO NOT ROUTE TACHOMETER LEADS WITH PRIMARY IGNITION WIRING.

DT9803

Connect the magnetic pickup cable conductors to the MPU terminal as shown in **Figure 1**. Use a two conductor shielded cable between the DT9803 and the magnetic pickup.

Figure 1: DT9803 typical wiring

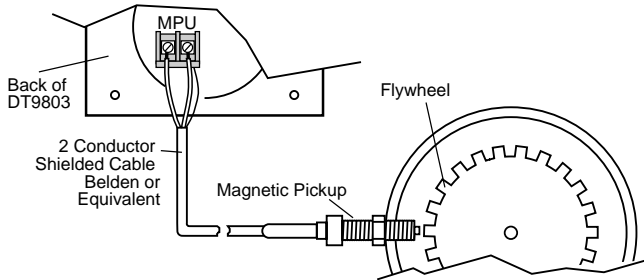

DT9804

Before wiring the DT9804, determine the output voltage and ground polarity of the ignition. **Table 1** lists the Peak Output Voltage and Ground Polarity of some common ignitions.

Connect the DT9804 tachometer to the CD ignition. **Figure 2** shows a typical wiring diagram for negative ground ignition system.

Figure 2: DT9804 typical wiring for negative ground ignition

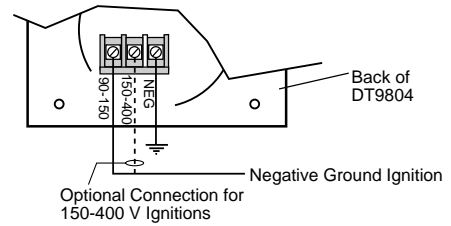

Table 1: Output Voltage & Polarity of Common CD Ignitions

Ignition MFG & Series	Ground Polarity	Peak Output Voltage	Use Figure
Altronic I, III, & V	Negative	120	6
Altronic II	Positive	350	7
Bendix S-1800, BLAR	Negative	250	6
Bendix Side-winder	Positive	300	7
Fairbanks Morse SC5A	Positive	180	7
Fairbanks Morse 3000 & 9000	Negative	225	6
American Bosch Magtronic	Negative	165	6

DT9805 AND DT9806 TYPICAL WIRING



WARNING: PERFORM THE WIRING INSTALLATION WITH THE POWER SOURCE OFF. DO NOT ROUTE TACHOMETER LEADS WITH PRIMARY IGNITION WIRING.

DT9805

1. Connect the magnetic pickup as shown in **Figure 3**.
2. Connect the overspeed switch wiring as shown **Figures 3 and 4**. Observe the polarity of the overspeed switch. The positive terminal must be connected to the positive side of the circuit as shown.
3. If connecting to a Murphy LCDT annunciator refer to **Figure 5**. See General Catalog for more information on the LCDT.

Figure 3: DT9805 typical wiring for negative ground ignition

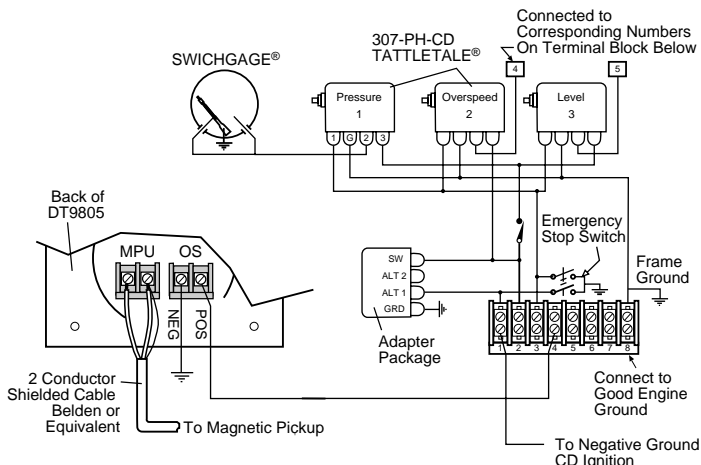

Figure 4: DT9805 typical wiring for positive ground ignition

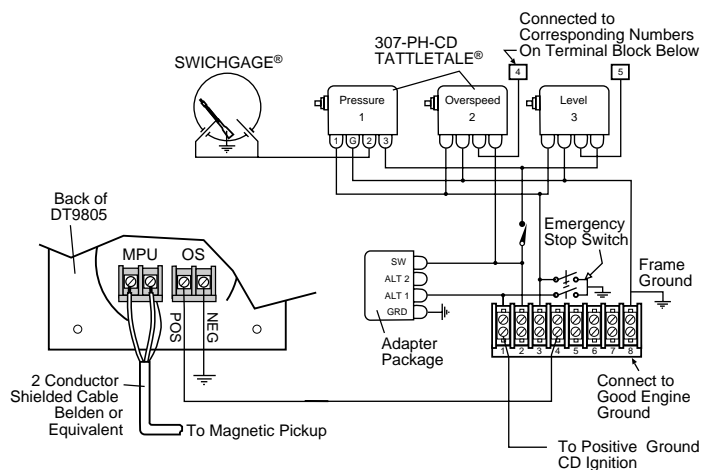
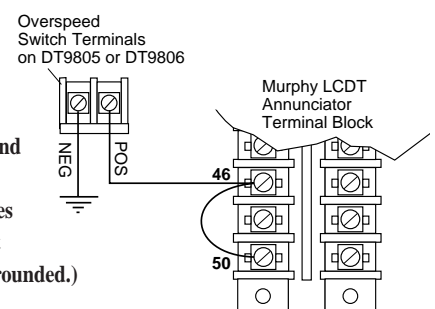

Figure 5: DT9805 and DT9806 negative ground connection to Murphy LCDT (for positive ground ignitions, reverse the negative and positive wires on the tachometer so that the positive terminal is grounded.)



DT9806

Before wiring the DT9806, determine the output voltage and ground polarity of the ignition. **Table 1** lists the Peak Output Voltage and Ground Polarity of some common ignitions.

Figure 6 displays wiring to a negative ground ignition and **Figure 7** for positive ground units. If the ignition output voltage is 90-150 volts, connect the ignition lead to the 90-150 input terminal on the DT9806; if it is 150-400 volts, then connect the lead to the 150-400 terminal.

Figure 6: DT9806 typical wiring for negative ground ignition

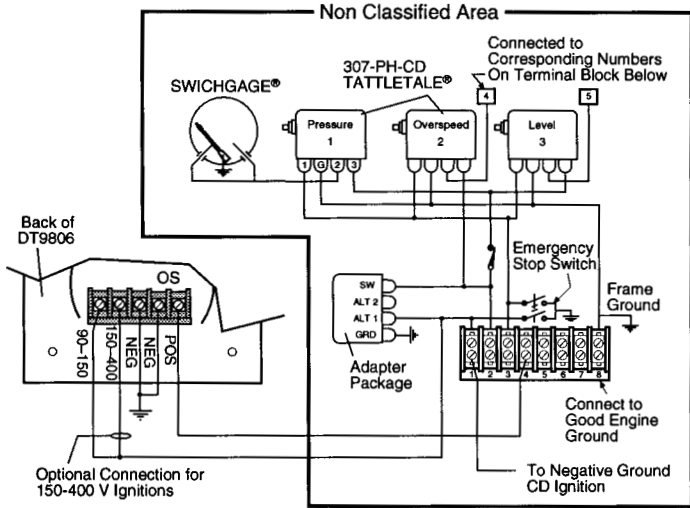
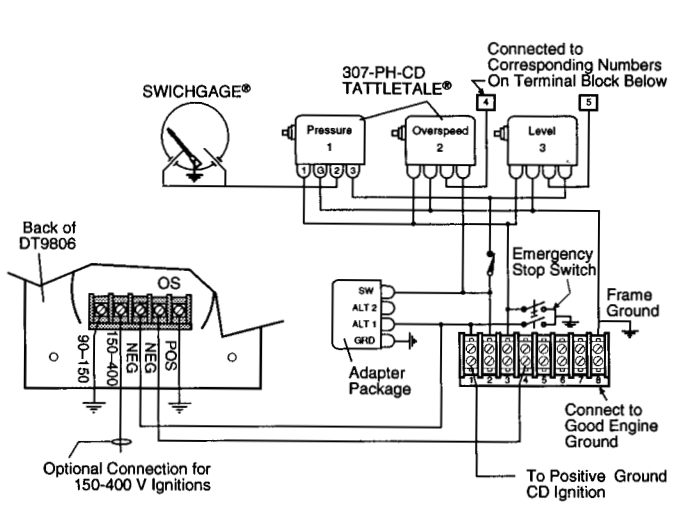
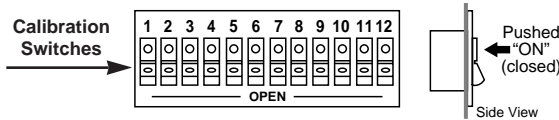

Figure 7: DT9806 typical wiring for positive ground ignition



CALIBRATING THE DT9800 SERIES TO YOUR ENGINE

1. Locate the calibration switches on back of the unit (see page 1).
2. If calibrating the DT9804 and DT9806 advance to step 3. If calibrating the DT9803 and DT9805, find the number of teeth for your gear in **Table 2**. Close the series of calibration switches listed next to the number of gear teeth.



DO NOT USE A PENCIL TO PUSH SWITCHES

3. To set the calibration code on the DT9804 and DT9806, refer to **Table 3**. Find the line that matches your engine's cylinders and cycles and set the DT9804/DT9806 according to the switches marked "ON".

NOTE: if the ignition system has two energy storage capacitors, count only half the actual number of engine cylinders for the calibration code.

Table 2: DT9803 and DT9805 Calibration Chart

Number of Gear Teeth	Close Switch Number(s)	Number of Gear Teeth	Close Switch Number(s)	Number of Gear Teeth	Close Switch Number(s)	Number of Gear Teeth	Close Switch Number(s)
250	2-3-5-6-7-8	225	1-5-9	200	1-2-5-6-9	175	1-2-3-4-5-7-9
249	1-2-3-5-6-7-8	224	2-5-9	199	1-3-5-6-9	174	1-6-7-9
248	4-5-6-7-8	223	3-5-9	198	2-3-5-6-9	173	1-2-6-7-9
247	1-4-5-6-7-8	222	1-3-5-9	197	4-5-6-9	172	1-3-6-7-9
246	2-4-5-6-7-8	221	2-3-5-9	196	1-4-5-6-9	171	1-2-3-6-7-9
245	1-2-4-5-6-7-8	220	2-3-5-9	195	1-2-4-5-6-9	170	1-4-6-7-9
244	3-4-5-6-7-8	219	1-4-5-9	194	1-3-4-5-6-9	169	3-4-6-7-9
243	1-3-4-5-6-7-8	218	2-4-5-9	193	2-3-4-5-6-9	168	2-3-4-6-7-9
242	2-3-4-5-6-7-8	217	1-2-4-5-9	192	7-9	167	5-6-7-9
241	1-2-3-4-5-6-7-8	216	3-4-5-9	191	2-7-9	166	2-5-6-7-9
240	9	215	2-3-4-5-9	190	1-2-7-9	165	3-5-6-7-9
239	1-9	214	1-2-3-4-5-9	189	1-3-7-9	164	1-2-3-5-6-7-9
238	2-9	213	6-9	188	1-2-3-7-9	163	1-4-5-6-7-9
237	1-2-9	212	2-6-9	187	1-4-7-9	162	1-2-4-5-6-7-9
236	3-9	211	1-2-6-9	186	2-4-7-9	161	2-3-4-5-6-7-9
235	1-3-9	210	1-3-6-9	185	3-4-7-9	160	8-9
234	1-2-3-9	209	2-3-6-9	184	2-3-4-7-9	159	2-8-9
233	4-9	208	1-2-3-6-9	183	5-7-9	158	1-3-8-9
232	1-4-9	207	1-4-6-9	182	2-5-7-9	157	1-2-3-8-9
231	2-4-9	206	2-4-6-9	181	1-2-5-7-9	156	2-4-8-9
230	1-2-4-9	205	3-4-6-9	180	1-3-5-7-9	155	3-4-8-9
229	3-4-9	204	1-3-4-6-9	179	1-2-3-5-7-9	154	1-2-3-4-8-9
228	1-3-4-9	203	1-2-3-4-6-9	178	1-4-5-7-9	153	1-5-8-9
227	1-2-3-4-9	202	5-6-9	177	1-2-4-5-7-9	152	3-5-8-9
226	5-9	201	2-5-6-9	176	1-3-4-5-7-9	151	1-2-3-5-8-9

150	2-4-5-8-9	120	10	90	1-2-4-6-8-10	60	11
149	3-4-5-8-9	119	3-10	89	2-5-6-8-10	59	1-5-11
148	1-2-3-4-5-8-9	118	1-4-10	88	2-4-5-6-8-10	58	1-2-6-11
147	2-6-8-9	117	1-3-4-10	87	2-7-8-10	57	2-3-5-6-11
146	1-3-6-8-9	116	1-5-10	86	2-4-7-8-10	56	1-4-7-11
145	4-6-8-9	115	2-3-5-10	85	1-2-5-7-8-10	55	1-3-4-5-7-11
144	1-2-4-6-8-9	114	1-2-4-5-10	84	1-2-4-5-7-8-10	54	2-5-6-7-11
143	2-3-4-6-8-9	113	6-10	83	3-6-7-8-10	53	1-2-3-8-11
142	1-5-6-8-9	112	1-3-6-10	82	3-4-6-7-8-10	52	2-3-4-5-8-11
141	3-5-6-8-9	111	2-4-6-10	81	1-2-3-5-6-7-8-10	51	1-3-5-6-8-11
140	1-2-3-5-6-8-9	110	1-2-3-4-6-10	80	9-10	50	1-3-4-7-8-11
139	2-4-5-6-8-9	109	3-5-6-10	79	2-4-9-10	49	2-3-6-7-8-11
138	1-3-4-5-6-8-9	108	1-4-5-6-10	78	3-5-9-10	48	9-11
137	7-8-9	107	2-3-4-5-6-10	77	2-3-4-5-9-10	47	1-2-4-5-9-11
136	3-7-8-9	106	3-7-10	76	4-6-9-10	46	4-5-6-9-11
135	1-2-3-7-8-9	105	1-4-7-10	75	1-2-5-6-9-10	45	1-3-5-7-9-11
134	1-2-4-7-8-9	104	1-2-3-4-7-10	74	2-3-4-5-6-9-10	44	3-5-6-7-9-11
133	2-3-4-7-8-9	103	1-3-5-7-10	73	2-4-7-9-10	43	1-3-5-8-9-11
132	1-5-7-8-9	102	2-4-5-7-10	72	1-3-5-7-9-10	42	1-2-3-5-6-8-9-11
131	1-3-5-7-8-9	101	6-7-10	71	1-6-7-9-10	41	1-2-4-5-7-8-9-11
130	1-4-5-7-8-9	100	2-3-6-7-10	70	2-3-6-7-9-10	40	10-11
129	3-4-5-7-8-9	99	1-3-4-6-7-10	69	2-4-5-6-7-9-10	39	1-2-3-6-10-11
128	6-7-8-9	98	1-2-5-6-7-10	68	4-8-9-10	38	1-5-7-10-11
127	3-6-7-8-9	97	4-5-6-7-10	67	1-3-5-8-9-10	37	1-3-4-5-6-7-10-11
126	4-6-7-8-9	96	8-10	66	1-2-6-8-9-10	36	1-2-4-6-8-10-11
125	3-4-6-7-8-9	95	1-2-3-8-10	65	1-5-6-8-9-10	35	1-2-4-5-7-8-10-11
124	1-2-3-4-6-7-8-9	94	2-3-4-8-10	64	7-8-9-10	34	1-2-3-4-9-10-11
123	3-5-6-7-8-9	93	1-3-5-8-10	63	1-2-3-4-7-8-9-10	33	2-3-7-9-10-11
122	4-5-6-7-8-9	92	3-4-5-8-10	62	1-2-3-4-5-7-8-9-10	32	8-9-10-11
121	3-4-5-6-7-8-9	91	1-2-6-8-10	61	1-2-3-4-6-7-8-9-10		

Table 3: Calibration Code for DT9804 and DT9806

Number of Cylinders	Number of Cycles	Calibration Switch Code												
		1	2	3	4	5	6	7	8	9	10	11	12	
1	2	—	—	—	—	—	—	—	—	—	—	ON	ON	—
2	2	—	—	—	—	—	—	—	—	—	—	ON	ON	—
2	4	—	—	—	—	—	—	—	—	—	—	ON	ON	—
3	2	—	—	—	—	—	—	—	—	—	—	—	ON	—
4	2	—	—	—	—	—	—	—	—	—	—	ON	ON	—
4	4	—	—	—	—	—	—	—	—	—	—	ON	ON	—
5	2	—	—	ON	—	ON	ON	—	—	—	—	ON	—	—
5	4	—	—	—	ON	—	ON	ON	—	—	—	ON	—	—
6	2	—	—	—	—	—	—	—	—	—	—	ON	—	—
6	4	—	—	—	—	—	—	—	—	—	—	ON	—	—
8	2	—	—	—	—	—	—	—	ON	ON	—	—	—	—
8	4	—	—	—	—	—	—	—	ON	ON	—	—	—	—
10	4	—	—	ON	—	ON	ON	—	—	—	—	ON	—	—
12	4	—	—	—	—	—	—	—	—	—	—	ON	—	—
16	4	—	—	—	—	—	—	—	—	—	—	ON	ON	—

Consult Murphy for Cylinder and Cycle combinations not listed on this table

SETTING OVERSPEED SET POINTS: DT9805 AND DT9806

The overspeed set point switches are available on the DT9805 and DT9806 **only**. The overspeed set point can be set within ± 5 RPM, over a range of 0010 to 9990 RPM. Setting of the overspeed set points is made by properly adjusting of three rotary switches. Each switch can be adjusted in increments of ten. To set the switches perform the following:

1. Locate the three rotary switches on the back of the unit (**Figure 8**).
2. Insert a small blade screwdriver inside the arrow slot. Turn the screwdriver until the arrow pointer is facing the number you choose.

EXAMPLE: You want the overspeed to trip at 1850 RPM (**Figure 8**):

- (1) Rotate the X-1000-arrow to the (1),
- (2) Rotate the X-100-arrow to the (8),
- (3) Rotate the X-10-arrow to the five (5).

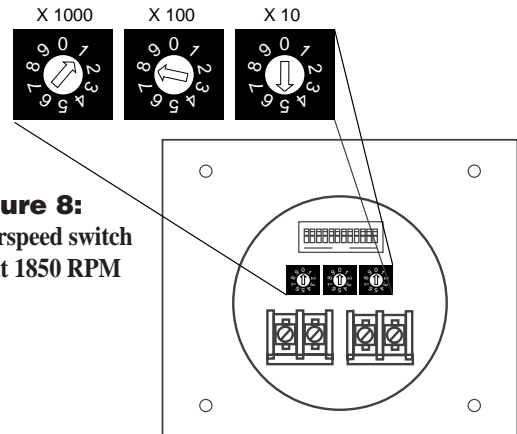

Figure 8:
Overspeed switch
set at 1850 RPM

DT9804 AND DT9806 TROUBLESHOOTING

If the DT9804 or DT9806 tachometer reading is incorrect or erratic follow the steps below in order until the devices read properly.

1. Check for proper voltage for your ignition system (90-150).
2. Check all grounds, be sure they are good and tight.
3. Separate ignition wires from primary coil wires.
4. Check switches for correct settings according to the number of engine cylinders. Where the ignition system has two storage capacitors, the tachometer must be set for half the number of engine cylinders.
DO NOT USE A PENCIL TO PUSH SWITCHES.
5. Check reading on 110 VAC 60 Hz with all switches open or on 0. The display should read all 0's. Also refer to the calibration chart in step 9.
6. The shutdown lead must be separated at least 12 in. (305 mm) from the high-tension spark plug leads. The best practice is to run the shutdown lead from the junction box to the panel in a separate conduit.

7. The common ground for the capacitor discharge ignition system coils must be grounded to the engine block, preferably as close to each coil as possible.
8. If the Murphy adaptor package is used make sure the tach is connected to the input (ALT 1, ALT 2) not the output.
9. Calibration Check: Hook 110 VAC 60 Hz hot to the input 90-150 and the neutral to the negative input. These readings are ± 1 RPM.

Dip Switches On	Reading
2, 4, 5	60
1, 5, 9	639
3, 6, 10	1284
2, 8, 11	2704
1, 7, 12	4951

Warranty

A two-year limited warranty on materials and workmanship is given with this Murphy product. Details are available on request and are packed with each unit.

In order to consistently bring you the highest quality, full featured products, we reserve the right to change our specifications and designs at any time.



■ **Frank W. Murphy Manufacturer**
P.O. Box 470248; Tulsa, Oklahoma 74147; USA
tel. (918) 627-3550 fax (918) 664-6146
e-mail fwmurphy@ionet.net

■ **Frank W. Murphy Southern Division**
P.O. Box 1819; Rosenberg, Texas 77471; USA
tel. (281) 342-0297 fax (281) 341-6006
e-mail murphysd@intertex.net

■ **Frank W. Murphy, Ltd.**
Church Rd.; Laverstock, Salisbury SP1 1QZ; U.K.
tel. +44 1722 410055 fax +44 1722 410088 tx 477088
e-mail sales@fwmurphy.co.uk

■ **Frank W. Murphy Pte., Ltd.**
26 Siglap Drive; Republic of Singapore 456153
tel. +65 241-3166 fax +65 241-8382
e-mail fwmsales@fwmurphy.com.sg

■ **Murphek Pty., Ltd.**
1620 Hume Highway; Campbellfield, Vic 3061; Australia
tel. +61 3 9358-5555 fax +61 3 9358-5558

■ **Murphy de México, S.A. de C.V.**
Blvd. Antonio Rocha Cordero 300, Fracción del Aguaje
San Luis Potosí, S.L.P.; México 78384
tel. +52-48-206264 fax +52-48-206336
e-mail murmexsl@sanluis.podernet.com.mx

■ **Murphy Switch of California**
P.O. Box 900788; Palmdale, California 93590; USA
tel. (805) 272-4700 fax (805) 947-7570
e-mail sales@murphyswitch.com

■ **Frank W. Murphy France**
tel. +33 1 30 762626 fax +33 1 30 763989