

# DLA100 TANKTEND™ Level Monitoring System Installation and Operation Instructions

DLA-95120N  
Replaces #057558M  
Revised 11-96  
Section 15  
00-02-2018



Please read the following information before installing. A visual inspection of this product for damage during shipping is recommended before mounting. It is your responsibility to have a qualified person install this unit and make sure it conforms NFPA 70 (National Electrical Code) and 30A (Automotive and Marine Service Station Code) and any other applicable local codes.

## GENERAL INFORMATION

WARNING

BEFORE BEGINNING INSTALLATION OF THIS MURPHY PRODUCT

- ✓ Disconnect all electrical power to the machine.
- ✓ Make sure the machine cannot operate during installation.
- ✓ Follow all safety warnings of the machine manufacturer.
- ✓ Read and follow all installation instructions.

### Specifications

**Enclosure:** 14 gauge steel, NEMA 3R.

**Power Input (Operating Voltage):** 120 VAC, 50/60 Hz (Standard);  
220 VAC, 50/60 Hz (Optional, not UL listed).

**Laboratory Listing:** Listed for use in non-hazardous locations to gage flammable and combustible liquids.



### OPLHA SWICHGAGE®:

**Accuracy:** ±2% for the first and last quarters of the scale, the middle half of scale is ±1%.

**Geared Movement:** 302 and 304 stainless steel.

**Overrange:** Do not exceed 30% above full range.

**Sensing Element:** Bellows.

**Dial:** 4-1/2 in. (114 mm), white on black background.

### Description

The DLA100 Monitoring System continuously monitors the level in a fuel storage tank and displays this level on an easy to read 4-1/2 in. (114 mm) dial gage. Level is measured by the highly reliable bubbler method using a built-in air pump (120 VAC, 50/60 Hz; optional 220 VAC) and our OPLHAC level SWICHGAGE®. The DLA100 system is housed in a weather-proofed enclosure (NEMA 3R) with provision for pad locking.

Adjustable high and low level contacts operate alarm lights on the front of the DLA100. A SPDT dry contact is provided to operate a remote low level alarm. Because it has both high and low level switches, the DLA100 can be used as a tank filling alarm and a low fuel supply alarm. Level is indicated in linear measurement. Your tank supplier can provide you with a chart converting height measurement to gallons, liters, etc.

A UTKN tank plug kit is provided with the DLA100 and can be installed on an underground or above ground tank. This kit includes 12 ft. (3.66 m) x 1/4 in. (6 mm) diameter stainless steel tube and fittings for below ground tank installations. The tank plug is available in 2 NPT or 4 NPT.

The UTKN tank plug and the DLA100 must be interconnected by a length of copper tubing (1/4 in. 6 mm dia.) routed through conduit (1 in. 25 mm dia.). Copper tubing and conduit are supplied by the customer. The copper tubing allows tank static head pressure changes to be monitored on the OPLHAC SWICHGAGE®.

### Warranty

A two year limited warranty on materials and workmanship is provided with this Murphy product. Details are available on request and are packed with each unit.

### DLA100 Mounting Dimensions

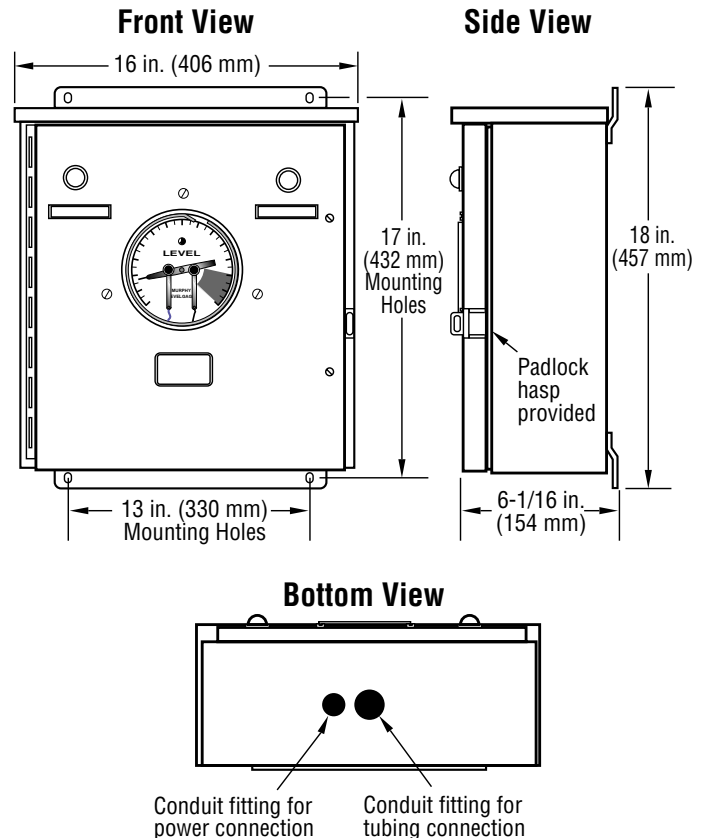

# INSTALLATION

**WARNING:** Installation of the DLA100 Series **MUST BE** made by a qualified installer. Hazardous conditions exist with flammable and corrosive products. Extinguish all smoking materials. Risk of explosion, fire and burning can cause serious or fatal injury.

## Mounting the DLA100

For Mounting Dimensions see page 1.

Mounting hardware is customer supplied. The mounting location for the DLA100 should provide unobstructed view of the gage and unobstructed access. Before mounting the DLA100, determine the routing of the sensor tubing and AC power line (routing through rigid conduit is recommended).

## Installing the Tank Plug Kit (UTKN)

The DLA100 includes a UTKN tank plug. Tank plug kit includes 12 ft. (3.6 m) x 1/4 in. (6 mm) dia. stainless steel tube and all necessary fittings.

The tank plug is available in 2 or 4 NPT.

1. Locate the tank service cover and install the UTKN tank plug.
2. From tank top to the DLA100 location, route a 1/4 in. (6 mm) dia. copper tube within a 1 in. (25 mm) dia. conduit. The customer is to supply the copper tube and the conduit. Caution must be exercised when routing copper tubing through conduit to avoid damaging the tube. Refer to Fig. 1 and Fig. 2.

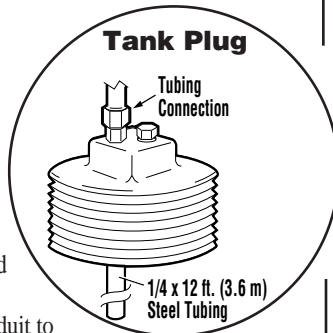

3. Before inserting the 1/4 in. (6 mm) dia. stainless steel tubing (probe) through tank plug fitting, make sure tubing can reach bottom and also will allow extra tubing for adjustments. Now lower the tubing until it touches bottom of the tank, do this as follows:

- A. Loosen the compression nut and the ferrule (see Detail A).
- B. Insert the tubing through the compression nut, ferrule and fitting until it touches bottom of tank.
- C. Mark tubing at top of fitting—raise the tubing exactly 3 in. (76 mm) off bottom and securely tighten ferrule and compression nut.
- D. Cut excess stainless steel tubing allowing 1/2 in. (13 mm) extension above the compression nut.

### Detail A

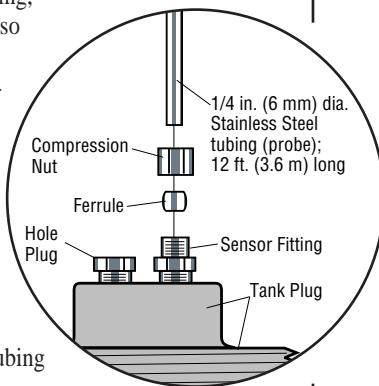

4. The copper tubing carries static head pressure from the stainless steel sensor tube within the tank to the DLA100.

Connect the copper tubing to the stainless steel tank probe as shown (see Detail B). The copper tubing should be continuous length—without splices.

5. Securely tighten all fittings, all connections must be air tight.

### Detail B

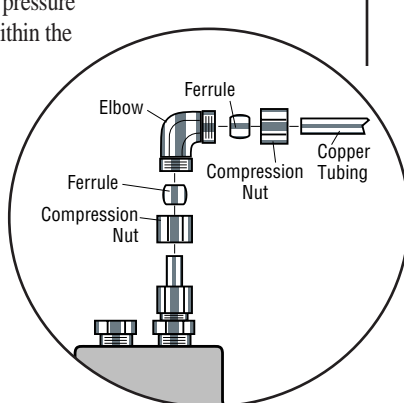

**Fig. 1 Typical Installation for Below Ground Tank**

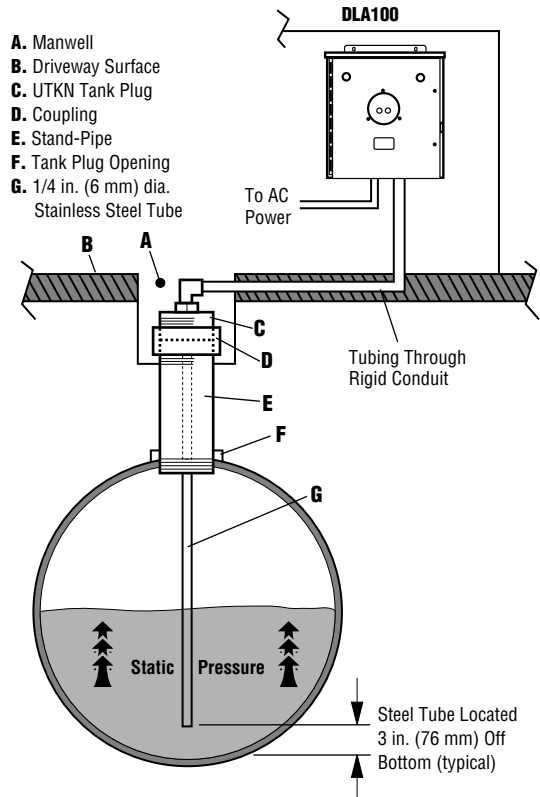

**Fig. 2 Typical Installation for Above Ground Tank**

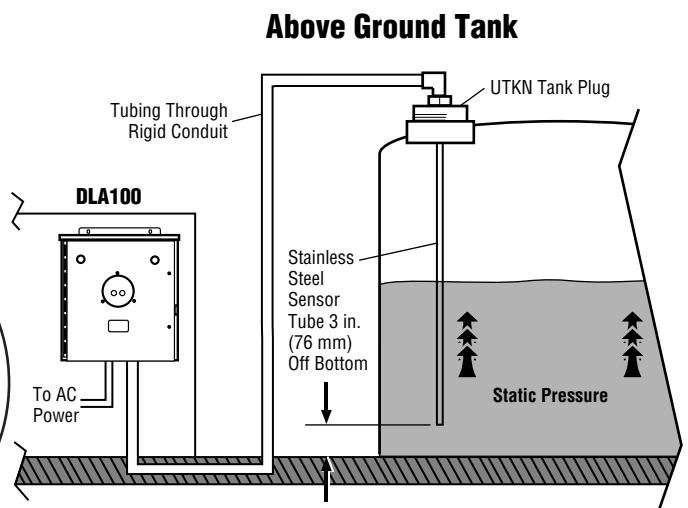

## INSTALLATION (continued)

### Connecting Copper Tubing to DLA100

The DLA100 includes a CKBO check valve, connected directly below the gage, within the DLA100 enclosure. This check valve is designed to prevent product from backing up into the gage. Connect the tubing line coming from the UTKN plug to the CKBO valve as follows:



**CAUTION:** Tubing line **MUST NOT** exceed 150 feet (45.7 m) from the tank for the DLA100 gage to read correctly. Contact Murphy for distances greater than 150 ft. (45.7 m).

1. Locate the CKBO check valve. It is connected to the OPLHAC SWICHGAGE®. Refer to Fig. 3, at right.
2. Completely detach the compression nut located at the end of the CKBO check valve (see Detail C).
3. Insert the copper tubing line through the compression nut and ferrule.
4. Route the copper tubing, the ferrule and the compression nut through the conduit fitting located directly below the check valve, at the bottom of the DLA100 enclosure.
5. Attach the copper tubing to the CKBO check valve fitting as shown.
6. Now, tighten the compression nut. Connection must be air tight.

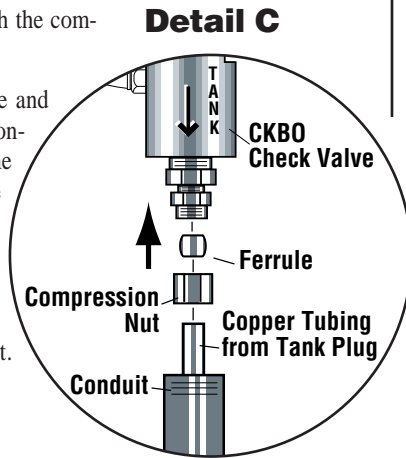

**Fig. 3 DLA100 Connections**

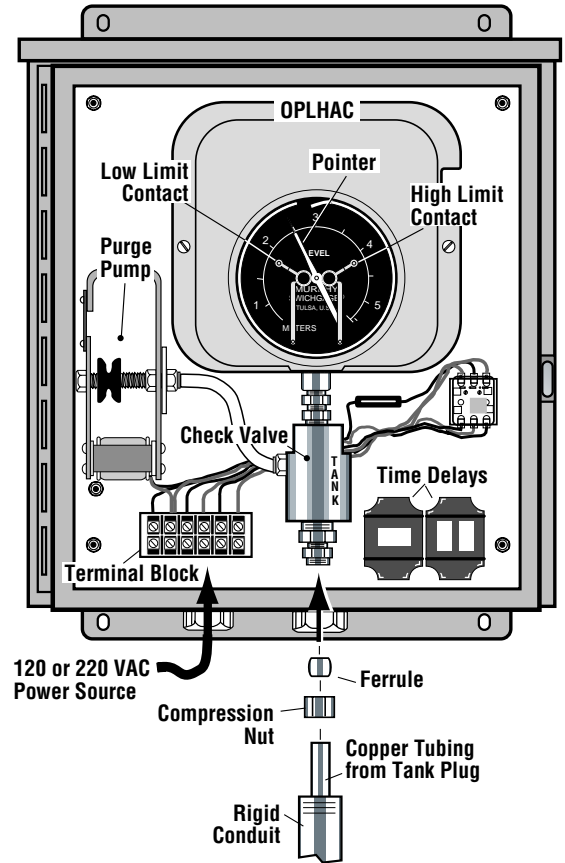

## ELECTRICAL CONNECTIONS



**WARNING:** Turn power "OFF" before wiring. Make sure voltage/current requirements are within the DLA100 ratings.

### Connecting AC Power to the DLA100

**IMPORTANT:** All connections must be made using appropriate wire size and wire termination hardware.

1. Locate the user terminal block within the DLA100 enclosure.
2. Route the wiring from the 120 or 220 VAC power source to the terminal block. Routing the power leads through conduit is recommended.
3. Connect the "L" power lead to DLA100 terminal #1, see Fig. 4, and Detail D.
4. Connect the "N" power lead to DLA100 terminal #2.

**Detail D**

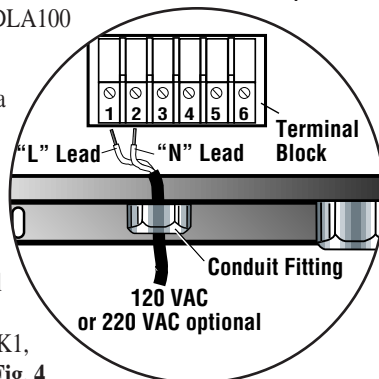

5. When connecting the DLA100 to a remote low level alarm, connect the remote alarm "N.O." lead to DLA100 terminal #3. Connect the "COMMON" lead to terminal #4. Connect "N.C." lead to terminal #5. Activation of external low level alarm is controlled by energizing/de-energizing of relay K1, see the Typical Wiring Diagram, Fig. 4.

**Fig. 4 Typical Wiring Diagram**

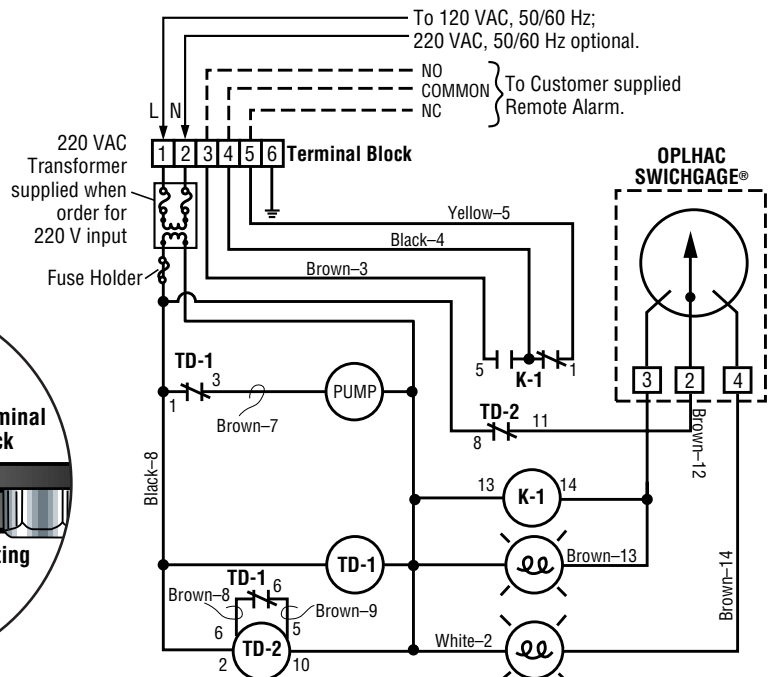

## ADJUSTING LIMIT CONTACTS AND GAGE POINTER

### Adjusting High and Low Limit Contacts

The OPLHAC SWICHGAGE® instrument features adjustable limit contacts. The OPLHAC is within the DLA100 enclosure. Facing the OPLHAC dial, the left knob is for adjusting the “Low Limit” contact. The “High Limit” contact knob is located on right.

1. Open the DLA100 enclosure door to access the gage. Determine “Low” product level where alarm activation is to occur. Gently turn the “Low Limit” contact knob to desired point on the scale.
2. Determine the “High” product level where alarm activation is to occur. Repeat the above procedure for the knob controlling the “High Limit” contact. Close enclosure door and latch.

### Limit Contacts Wiping Feature

The force of the pointer causes the flexible contact arm (A) to tilt resulting in a wiping action (D). This clears away film and corrosion formed on the contact surface, refer to **Detail E**.

- A. Contact arm-flex
- B. Contact arm
- C. Pointer Contact
- D. Initial point of contact
- E. Limit contact knob

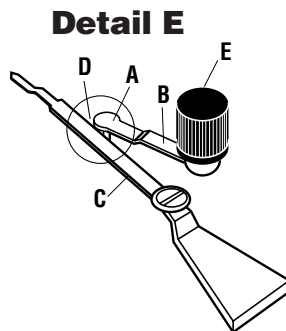

### Resetting the SWICHGAGE® Pointer

After the DLA100 has been connected, reset the pointer for proper level indication, proceed as follows. Allow the DLA100 system to complete 2 to 3 purge cycles before performing the following calibration steps:



**WARNING: Turn power OFF before resetting the gage pointer.**

1. Determine actual product level by a reliable means and record this value.
2. Use caution to remove the SWICHGAGE® snap ring and lens (place your hand on top of ring to protect against its spring action).
3. Carefully hold the pointer, as shown at **Detail F**, making sure not to bend it.
4. With a small screwdriver, turn the setting screw to corresponding reading value recorded in step 1. Clockwise to raise the pointer— counterclockwise to lower the pointer.
5. Replace the lens and snap ring.
6. Turn AC power ON. Check pointer position reading to be certain it agrees with calibrated setting after tank purging.

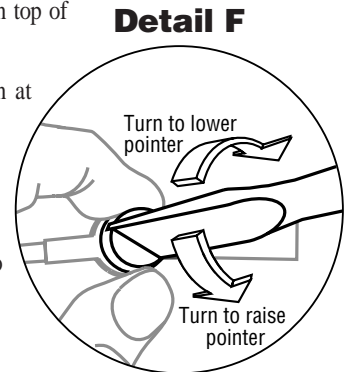

**NOTE: Span adjustments and recalibration must be performed by authorized mechanic or return the unit to Frank W. Murphy Mfr.**

## CIRCUIT OPERATION AND TEST

Perform the following circuit operation and test after the DLA100 system is completely installed and wired appropriately.

**Important:** The relay timers TD1 and TD2 must be set to your specifications before attempting this operation test. To set the relay timers, refer to the instructions provided by the relay manufacturer (included in your DLA100 system information package).

### Circuit Operation

A typical application for indication only of high and low level alarms for storage or supply tank, is achieved with the use of DLA100.

The TD1 relay timer controls the purge pump cycle “ON” and “OFF” times. The TD2 relay timer locks out the alarm contacts during the purge cycle. Relay TD2 stops any type of false alarm in a purge cycle.

The alarm indication will only be activated during the period when the indicating pointer is making contact with the low or high OPLHAC adjustable contact.

### Testing the DLA100

1. Apply power to the DLA100.
2. The purge pump will begin pumping. If the purge pump does not start, connect a voltmeter across terminals #1 and #2 to verify the correct AC voltage is being applied. Refer to “Electrical Connections” section on page 3. Check purge relay time settings or recycle time delay. Also check the fuse.
3. The SWICHGAGE® pointer will travel clockwise. Adjust the limit contacts to desired set points (see above section).
4. If override is necessary it must be done externally.
5. To test the limit contacts, turn the limit contact knob to be tested until the contact touches the pointer. That will trip the control circuit. Reset limit contact.

*In order to consistently bring you the highest quality, full featured products, we reserve the right to change our specifications and designs at any time.*



■ **Frank W. Murphy Manufacturer**  
P.O. Box 470248; Tulsa, Oklahoma 74147; USA  
tel. (918) 627-3550 fax (918) 664-6146  
e-mail fwmurphy@ionet.net

■ **Frank W. Murphy Southern Division**  
P.O. Box 1819; Rosenberg, Texas 77471; USA  
tel. (281) 342-0297 fax (281) 341-6006  
e-mail murphysd@intertex.net

■ **Frank W. Murphy, Ltd.**  
Church Rd.; Laverstock, Salisbury SP1 1QZ; U.K.  
tel. +44 1722 410055 fax +44 1722 410088 tlx 477088  
e-mail sales@fwmurphy.co.uk

■ **Frank W. Murphy Pte., Ltd.**  
26 Siglap Drive; Republic of Singapore 456153  
tel. +65 241-3166 fax +65 241-8382  
e-mail fwmsales@fwmurphy.com.sg

■ **Murphok Pty., Ltd.**  
1620 Hume Highway; Campbellfield, Vic 3061; Australia  
tel. +61 3 9358-5555 fax +61 3 9358-5558

■ **Murphy de México, S.A. de C.V.**  
Blvd. Antonio Rocha Cordero 300, Fracción del Aguaje  
San Luis Potosí, S.L.P.; México 78384  
tel. +52-48-206264 fax +52-48-206336  
e-mail murmexsl@sanluis.podernet.com.mx

■ **Murphy Switch of California**  
P.O. Box 900788; Palmdale, California 93590; USA  
tel. (805) 272-4700 fax (805) 947-7570  
e-mail sales@murphyswitch.com

■ **Frank W. Murphy France**  
tel. +33 1 30 762626 fax +33 1 30 763989