

Liquid Storage-Tank Level Monitoring System

with HIGH and LOW level alarms



- Continuous Analog Display of Level
- High and Low Level Alarm Lights
- Fingertip Adjustable Alarm Levels
- Relay for Remote Alarm of Low Level
- Listed for Use in Non-hazardous Locations, to Gage Flammable and Combustible Liquids



Description

The DLA100 TANKTEND™ Monitoring System continuously monitors the level in a fuel storage tank and displays the level on an easy to read 4-1/2 in. (114 mm) dial gage. Level is measured by the highly reliable bubbler method using a built-in air pump (120 VAC, 50/60 Hz; optional 220 VAC*) and our OPLHAC level SWICHGAGE®.

Adjustable high and low level contacts operate alarm lights on the front of the DLA100. A SPDT dry contact is also provided to operate a remote low level alarm.

Applications

Because it has both high and low switches, the DLA100 can be used as a tank filling alarm and a low fuel supply alarm.

The enclosure is a NEMA 3R weatherproof enclosure with provision for pad locking.

Level is indicated in linear measurement. Your tank supplier can provide you with a chart converting height measurement to gallons, liters, etc. The following scales are available.

Ranges:

- 0-60 in. (0-1.52 m)
- 0-96 in. (0-2.43 m)
- 0-126 in. (0-3.2 m)
- 0-144 in. (0-3.66 m)
- 0-3.6 meter
- 0-4 meter



Dimensions

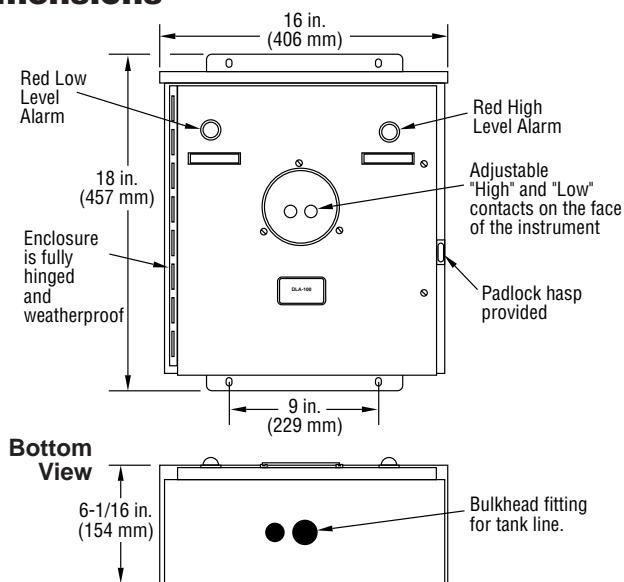

UTKN

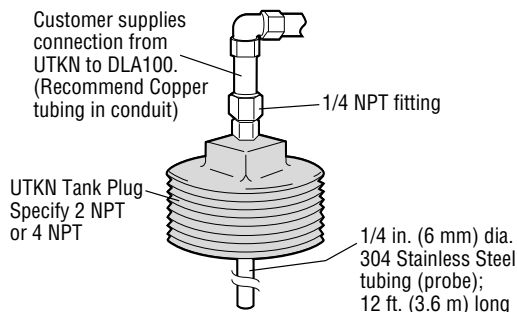

Tank Plug Kit: This kit includes 12 ft. (3.66 m) x 1/4 in. (6 mm) diameter stainless steel tube, and fittings for below ground tank installations. The tank plug is available in 2 NPT or 4 NPT and is included with the DLA100 (See "How to Order" on reverse side).

*Not UL listed.

Below Ground Tank Recommended Installation (Stand-Pipe Method)

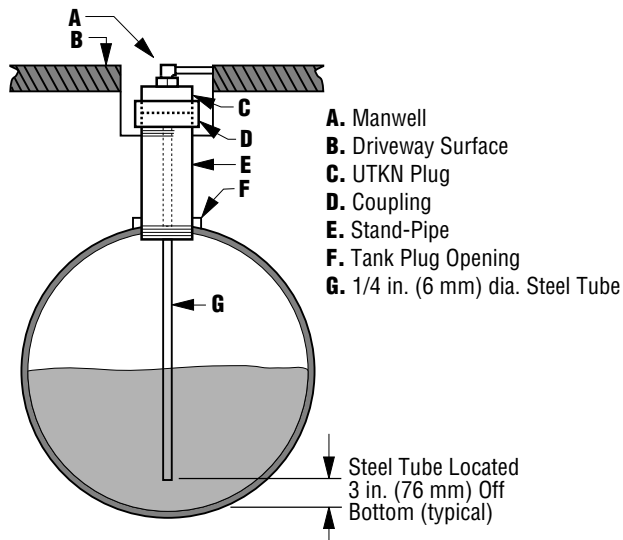

The above method of installation allows for future access should probe tube height adjustments need to be made due to tank settlement, or system troubleshooting.

How to Order

DLA100 - - - - -

Liquid
W = Water
D = Diesel
G = Gasoline

Optional Voltage
Blank = 120 VAC, 50/60 Hz
220 = 220 VAC, 50/60 Hz
(Not UL listed)

Tank Height
060 = 60" Scale
096 = 96" Scale
126 = 126" Scale
144 = 144" Scale
03M = 3.6 Meter Scale
04M = 4 Meter Scale

Tank Plug Size
2 = 2 NPT
4 = 4 NPT

Shipping Weights:

- DLA100 (tube not included): 45 lbs (20 kg.)
- 12 ft. (3.66 m) Tube: 6 lbs (3 kgs)

Shipping Dimensions:

- DLA100: 19-1/2 x 20 x 18 in. (495 x 508 x 457 mm)
- 12 ft. Tube: 5 in. x 5 in. x 12 ft. (127 mm x 127 mm x 3.66 m)

Warranty

A two-year warranty on material and workmanship is provided with this Murphy product. Details are available on request and are packed with each unit.

Above Ground Tank

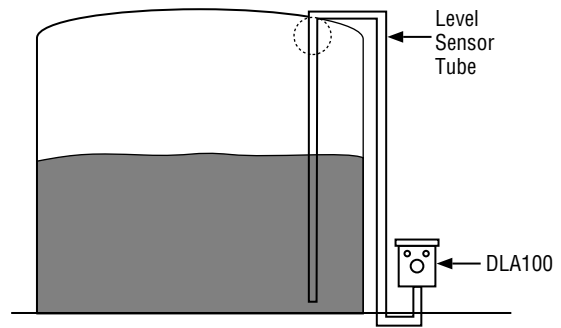

NOTE: Tubing for DLA100 must not exceed 150 ft. (45.7 m) from tank for gage to read correctly. Distances greater than 150 ft. require a special quote.

Wiring

Time delay relay TD-1 controls the purge pump cycle "on" and "off" times and TD-2 locks out the alarm contacts during the purge cycle. TD-2 stops any type of false alarm in a purge cycle. The delays are field-set (1-1023 seconds) in 1 second intervals.

The alarm indication will only be activated during the period when the indicating pointer is making contact with the high or low OPLHAC SWICHGAGE® adjustable contacts.

The static head pressure is read by connecting a pressure line from the DLA100 to the UTKN Tank probe in the storage or supply tank, the loss or gain of the static head pressure is the controlling signal to change the readout.

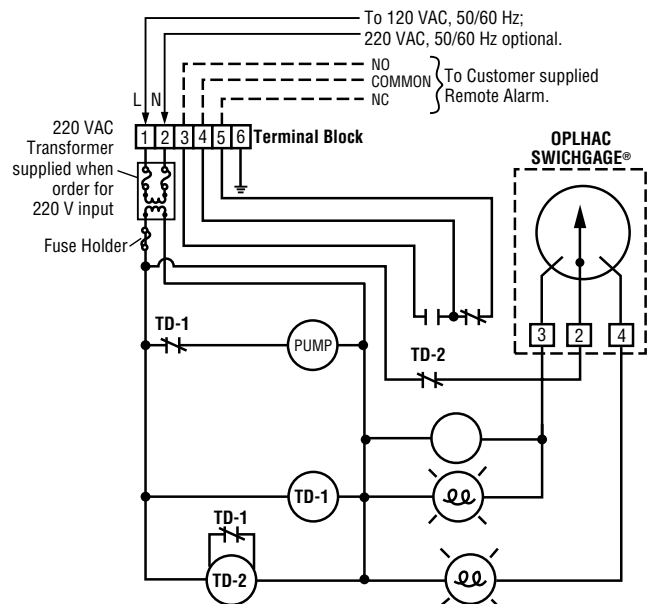

In order to consistently bring you the highest quality, full featured products, we reserve the right to change our specifications and designs at any time.



■ **Frank W. Murphy Manufacturer**
P.O. Box 470248; Tulsa, Oklahoma 74147; USA
tel. (918) 627-3550 fax (918) 664-6146
e-mail fwmurphy@ionet.net

■ **Frank W. Murphy Southern Division**
P.O. Box 1819; Rosenberg, Texas 77471; USA
tel. (281) 342-0297 fax (281) 341-6006
e-mail murphysd@intertex.net

Printed in U.S.A.

■ **Frank W. Murphy, Ltd.**
Church Rd.; Laverstock, Salisbury SP1 1QZ; U.K.
tel. +44 1722 410055 fax +44 1722 410088 tlx 477088
e-mail sales@fwmurphy.co.uk

■ **Frank W. Murphy Pte., Ltd.**
26 Siglap Drive; Republic of Singapore 456153
tel. +65 241-3166 fax +65 241-8382
e-mail fwmsales@fwmurphy.com.sg

■ **Murphok Pty., Ltd.**
1620 Hume Highway; Campbellfield, Vic 3061; Australia
tel. +61 3 9358-5555 fax +61 3 9358-5558

■ **Murphy de México, S.A. de C.V.**
Blvd. Antonio Rocha Cordero 300, Fracción del Aguaje
San Luis Potosí, S.L.P.; México 78384
tel. +52-48-206264 fax +52-48-206336
e-mail murmexsl@infosel.net.mx

■ **Murphy Switch of California**
P.O. Box 900788; Palmdale, California 93590; USA
tel. (805) 272-4700 fax (805) 947-7570
e-mail sales@murphyswitch.com

■ **Frank W. Murphy France**
tel. +33 1 30 762626 fax +33 1 30 763989