

MURPHY®

by **ENOVATION** CONTROLS

EVS-2™

Electronic Vibration Switch



Installation and Operations Manual

00-02-0841
2013-04-25
Section 20

In order to consistently bring you the highest quality, full featured products, we reserve the right to change our specifications and designs at any time. The latest version of this manual can be found at www.fwmurphy.com.

Warranty – A limited warranty on materials and workmanship is given with this Murphy product. A copy of the warranty may be viewed or printed by going to <http://www.fwmurphy.com/warranty>.



Please read the following information before installing the EVS-2.

- This installation information is intended for all EVS-2 models. A visual inspection of this product before installation for any damage during shipping is recommended.
- Disconnect all power and be sure machine is inoperative before beginning installation.
- Installation is to be done only by qualified technician according to the National Electrical Code.
- Observe all Warnings and Cautions at each section in these instructions.
- Please contact MURPHY immediately if you have any questions.

MURPHY has made efforts to ensure the reliability of the Electronic Vibration Switch (EVS-2) and to recommend safe usage practices in system applications. Please note that in any application, operations and device failures can occur. These failures may result in full control outputs or other outputs which may cause damage to or unsafe conditions in the equipment or process connected to the EVS-2.

Good engineering practices, electrical codes, and insurance regulations require that you use independent external protective devices to prevent potentially dangerous or unsafe conditions. Assume that the Murphy EVS-2 system can fail with outputs full on, outputs full off, or that other unexpected conditions can occur.

Table of Contents

Product Information.....	1
Murphy EVS-2 Overview	1
EVS-2 Characteristics and Orientation.....	2
Installation.....	3
Mounting	3
Mounting Options	4
Bracket Proposals	5
Mounting Examples.....	5
Plug Options.....	6
Wiring.....	6
Settings.....	10
Setting the Set-Point in Inches Per Second (IPS) Peak.....	10
Setting of Alarms.....	13
Vibration Limits Based on Class of Equipment Based on ISO 10816-3	14
Equipment Manufacturer Recommended Settings.....	16
Specifications	17

THIS PAGE INTENTIONALLY LEFT BLANK

Product Information

Murphy EVS-2 Overview

The Murphy Electronic Vibration Switch (EVS-2) protects against equipment failure by monitoring velocity-based vibration levels and providing an early warning or shutdown when abnormal vibration is detected. The EVS-2 can be connected to Murphy's TTD™ annunciator, Centurion™, Centurion PLUS™ or any third-party controller that accepts a switch input or 4-20mA signal for increased functionality.

NOTE: The Murphy EVS-2 complements Murphy's VS2™ shock and excessive vibration switch, which is designed to detect an abnormal shock due to equipment failure and to shutdown other equipment in a system to prevent further damage.

Features

- Universal use, can be mounted horizontal, vertical or at any other angle
- Piezoelectric-crystal internal sensor with built-in microelectronics for reduced noise sensitivity
- Electronically integrated output signal that measures and trips on velocity (IPS peak)
- Two independently adjustable output channels
- Shutdown setpoint measured in velocity (IPS peak)
- 4-20 mA output for continuous monitoring capability
- Solid-state outputs for setpoint trip
- Adjustable time delay to prevent false tripping on high-vibration start-ups or non-repetitive transient events
- RAW 100mV/g output also available

Applications

The Murphy EVS-2 can be used on any equipment where abnormal vibration could lead to equipment damage, including:

Cooling fans
Engines
Pumps
Compressors
Gear boxes
Motors
Generator sets

The Murphy EVS-2 can monitor and alert the operator of abnormal vibration caused by a variety of possible factors, including:

Imbalance
Misalignments
Worn sleeve bearings
Broken tie down bolts
Worn ball or roller bearings
Gear mesh
Blade pass frequencies
Detonation
Broken parts

EVS-2 Characteristics and Orientation

To prevent damage to the EVS-2 vibration switch, the following vibrations may not be exceeded:

- Vibration 15 g
- Shock 150 g

Two-Channel LED Indicators

Two independent, adjustable level detectors with selectable delay times are equipped with corresponding relays which are typically used for Alarm and Shutdown. Both channels use the same vibration range selection.

Red and Yellow LED indicators representing these two channels are illuminated during normal use. When a fault is activated, the LED indicators will turn off.

IMPORTANT! Because the EVS-2 resets automatically when the vibration level returns below the set point, it is important to ensure that the fault has been addressed before restarting the equipment.

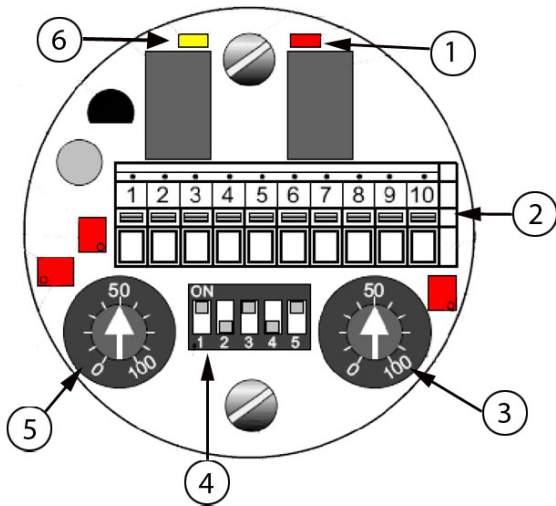

1	Red Channel 2 LED (K2)
2	Spring terminal 16-24 AWG.
3	Channel 2 (K2) Vibration Set Point Potentiometer (Pot)
4	DIP switches for vibration ranges and time delays.
5	Channel 1 (K1) Vibration Set Point Potentiometer (Pot)
6	Yellow Channel 1 (K1) LED

Figure 1 – Inside view of Murphy EVS-2 component locations

Installation

Mounting

The Murphy EVS-2 must be mounted and set in accordance with the guidelines in this manual to obtain the desired and specified performance and equipment protection.

Mounting occurs via a ½" NPT thread, the tightening torque is hand tight plus 2 to 3 turns.

When using a mounting bracket, ensure that mounting surfaces are smooth and flat.

Care must also be taken that the mounting surface is not subject to natural vibrations. Using a high stiffness mounting surface prevents natural vibrations which cause measurement errors.



WARNING! Exceeding the torque specification will damage the aluminum housing. If there is concern of the device becoming loose due to excessive vibration, use a permanent thread locker such as Loctite 271 (RED).

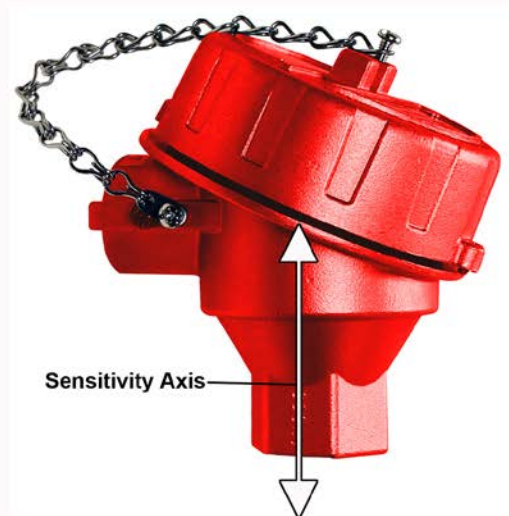
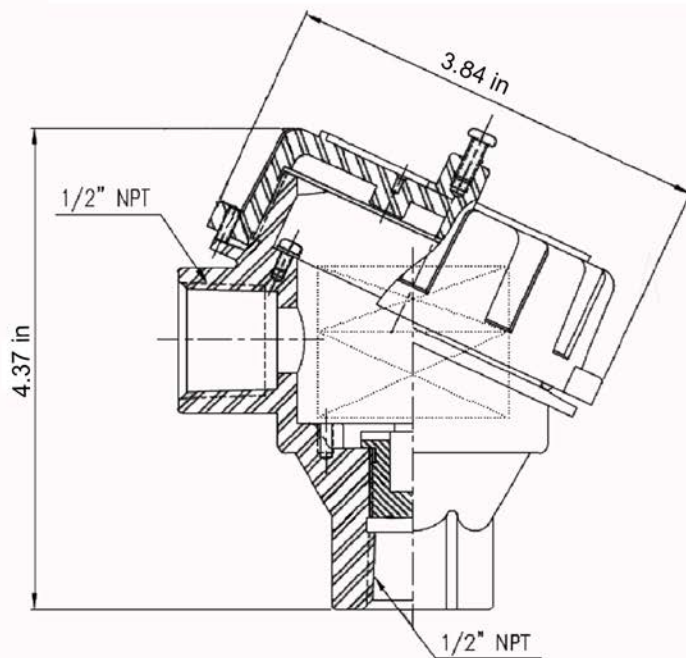
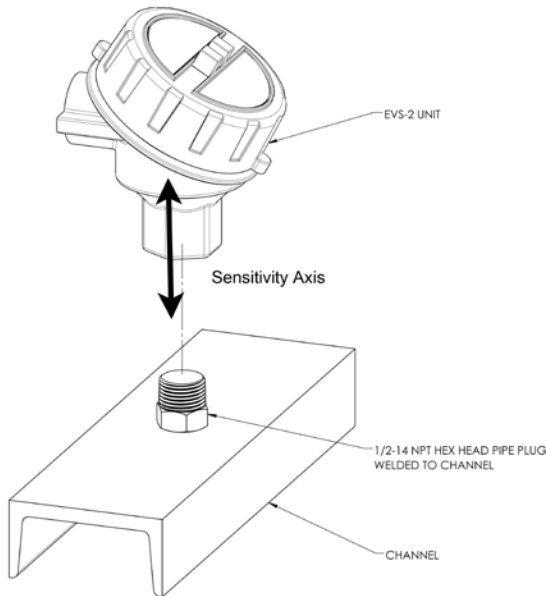

Figure 2 – Product Dimensions and Sensitivity Axis

Mounting Options

The following diagrams illustrate example mounting options for the EVS-2 using a simple pipe plug welded to the machine surface or a bracket with the special adapter provided for drilled and tapped surface mount.

NOTE: The special adapter is available for sale. Also note that a hollow pipe close nipple is NOT recommended for installations.



Channel Installation Option

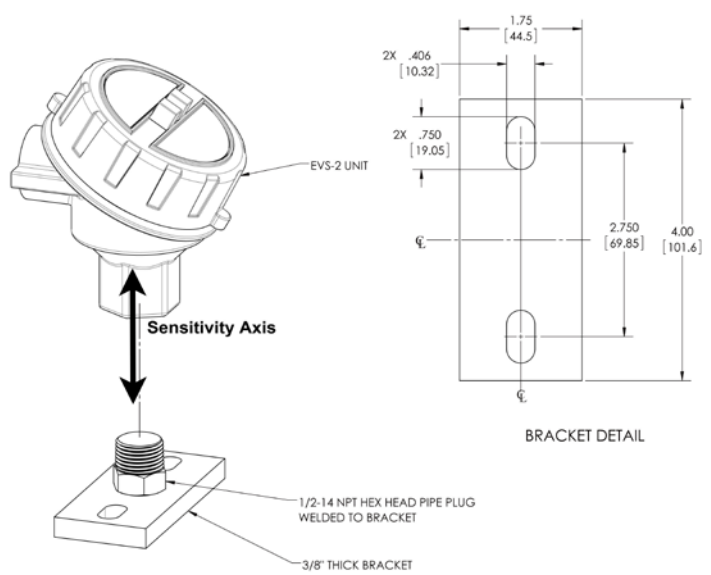

Bracket Installation Option

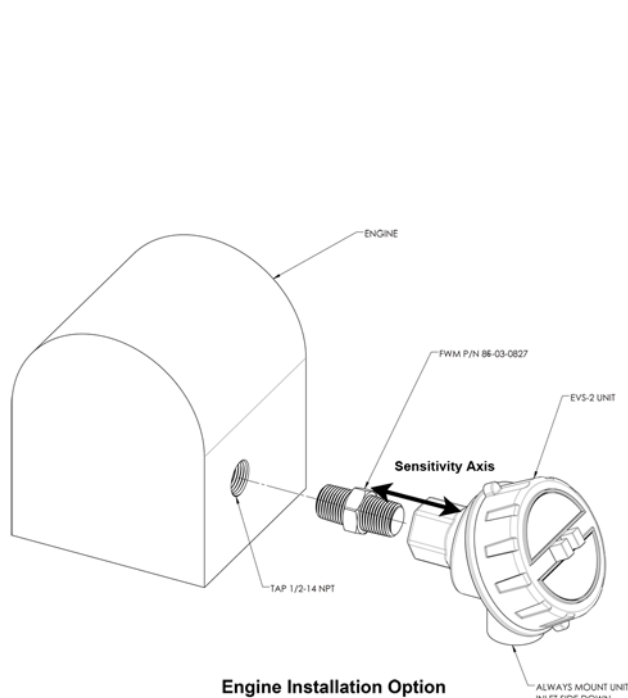

Engine Installation Option

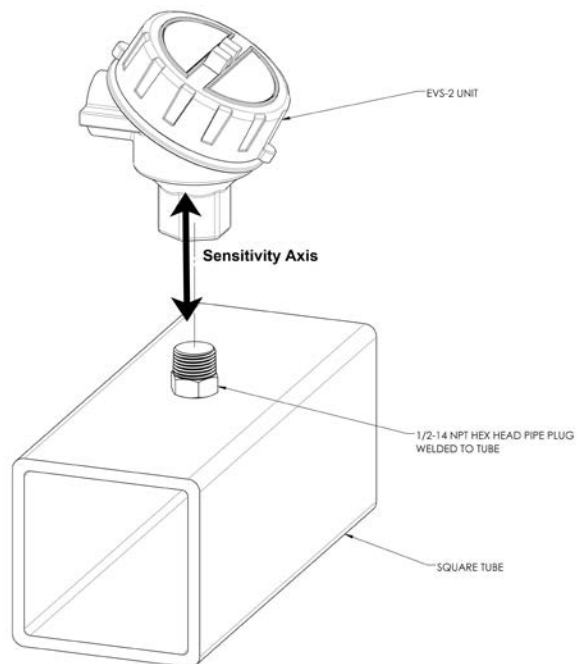

Square Tube Installation Option

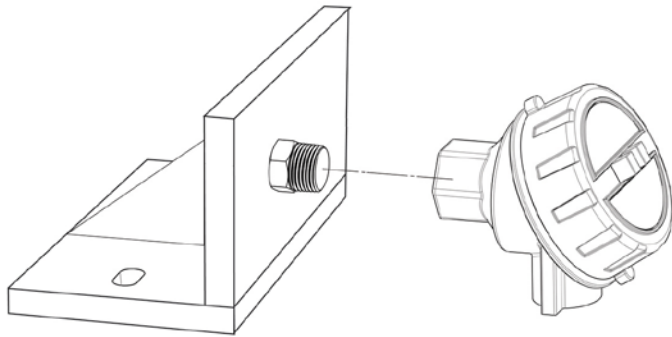

Center Support Bracket Installation Option

Bracket Proposals

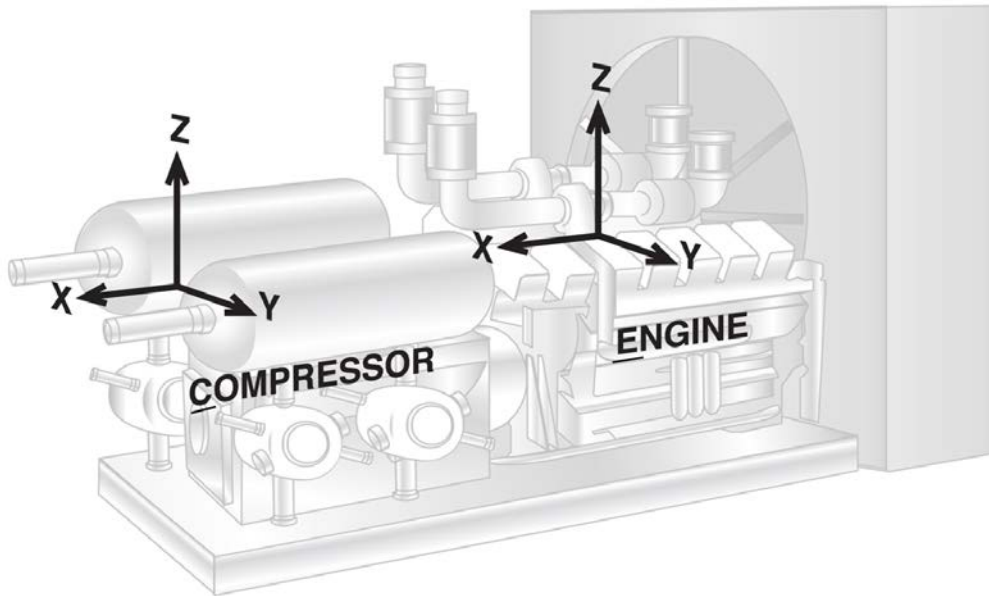

Mounting Examples

Legend: **C**=Compressor, **E**=Engine

Compressor	Engine
Cx (Compressor) = Crankshaft endplay	Ex (Engine) = Crankshaft endplay
Cy = Main Bearings, Rod Bearings	Ey = Main Bearings
Cz = Main Bearings	Ez = Main Bearings, Detonation, Rod Bearings

Plug Options

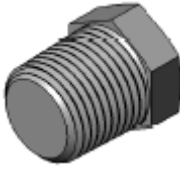
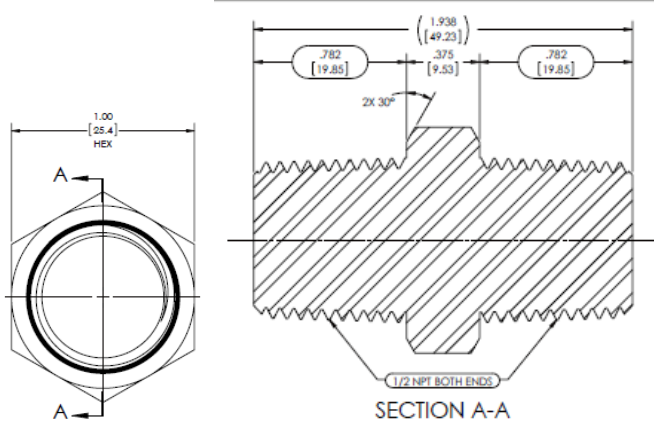
	<p>High-pressure (non-hollowed), forged steel pipe plug permanently welded to equipment or bracket surface. Be sure weld is clear of threads for maximum thread engagement.</p>
	<p>Optional Adapter available from Murphy: 1/2" NPT, High-pressure (non-hollowed), steel pipe plug, Male x Male to be used for direct mount to equipment with a 1/2" NPT threaded pilot hole. Part number 86-03-0827.</p>

Wiring

The method chosen to electrically connect to the switch should be mechanically flexible to eliminate the measurement of vibration induced from conduit and to provide a moisture barrier as well. Although Sealtite™ and other flexible conduit have been used successfully, in areas of extreme humidity or moisture Murphy recommends using an “SO” type cable along with a Div. 2 suitable rain-tight CGB Gland/Strain relief fitting. No stress should be possible on the wiring to the terminal block. If such protection is not provided by the conduit system, some form of stress relief must be installed.



WARNING! Certification compliance requires the use of a cable gland and strain relief fitting.

To assure compatibility with EMI compliance standards, any signal level wiring such as transducer or 4-20 mA wiring should use shielded cable in EMI proof conduit, separate from any power wiring except the DC power for the EVS-2. The 26-16 AWG wire can be used.

NOTE: It is strongly recommended that cabling be installed using the method defined in the Shipboard Cable/Cord Installation document (00-02-0725 rev 08/2010). That document can be found by following this link:

<http://www.fwmurphy.com/evs2>

Terminal Assignment

Terminal assignment		
1	PS	+ 24 V DC
2		0 V DC
3	Relay K1	NC
4		COM
5		NO
6	Relay K2	NC
7		COM
8		NO
9	Analog output 20 mA	
10	RAW Signal 100 mV/g	

Notes:

During NORMAL operation, the COM and N.O. will have continuity.

On a SHUTDOWN or POWER LOSS, the COM and N.C. will have continuity.

The power supply +24 VDC voltage is connected via terminals 1 and 2.

NOTE: Minimum voltage acceptable for normal operation is 20-30 VDC @ 40mA (powered by Class 2 supply).

A DC to DC converter can be used for 12V systems. Murphy recommends the Phoenix Contact MINI-PS-12-24DC/24DC/1 or equivalent.

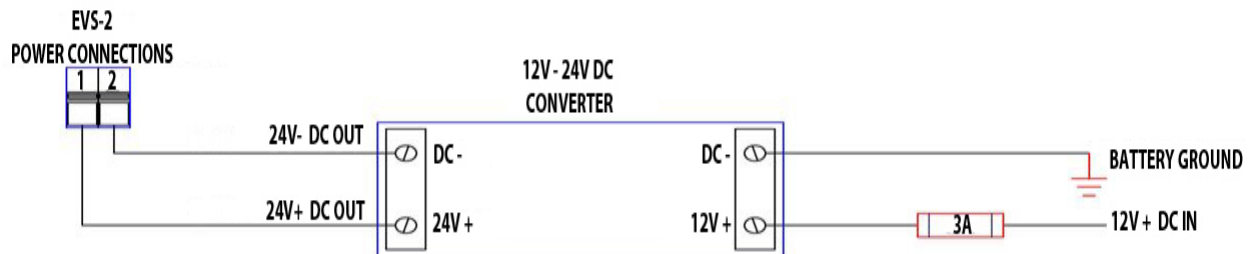

Non-latching relay outputs for Channel 1 (K1) and Channel 2 (K2) are present on terminals 3 through 8.

NOTE: On initial power-up:

Relays do not activate until the 4-20mA reading settles below the trip point for the corresponding channel.

Ex: If Channel 1 is set at 50%, the Relay will not activate on power-up until the 4-20 settles below 12mA. This could take approximately 7 seconds.

If the trip point is higher (90%) then it will take less time.

If the trip point is lower (10%) then it will take more time.

4-20mA Output requires approximately 30 seconds to reach full resolution.

Figure 3 - EVS-2 Hook-up (showing only how to wire Channel 1 {K1})

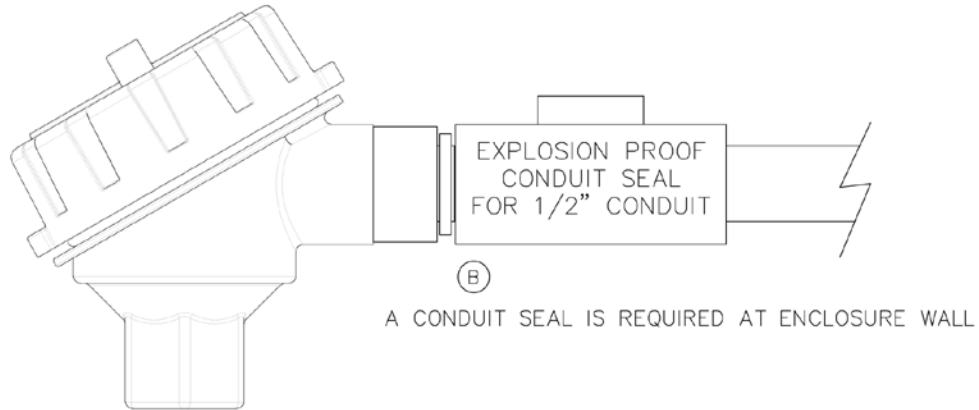

AWG 16 TO AWG 26 WIRE CAN BE USED
ONLY ONE AWG 16 CONDUCTOR,
OR 2 AWG 20, OR 4 AWG 22
WIRES CAN BE USED PER TERMINAL

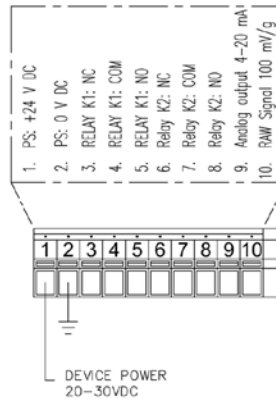

EVS-2 Wired to TTD as Normally Open
or as 2 wire

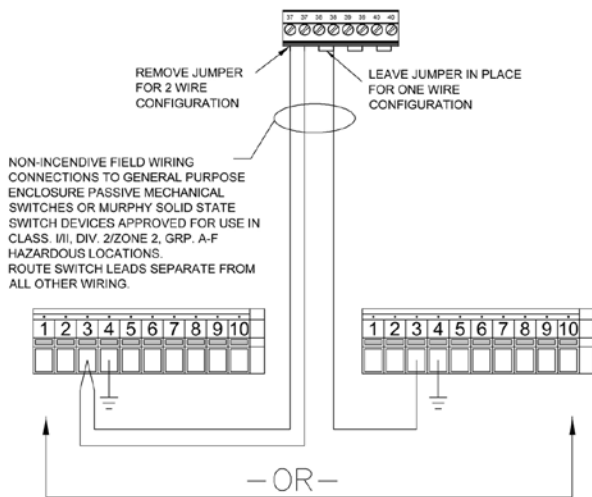

EVS-2 Wired to TTD as Normally Closed

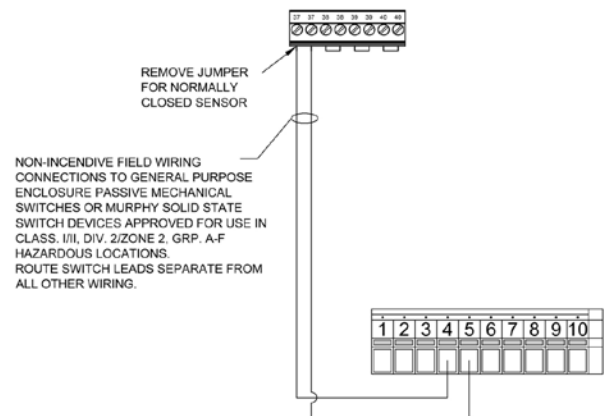
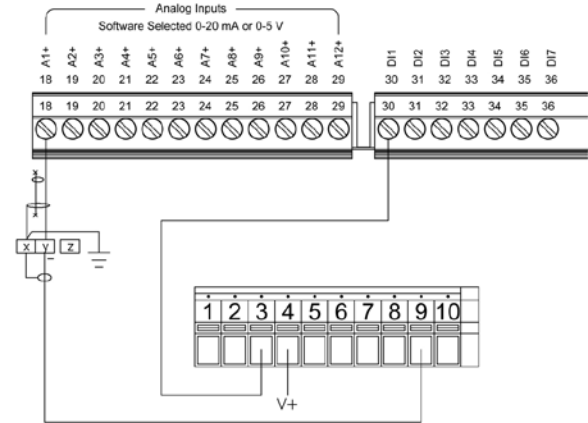
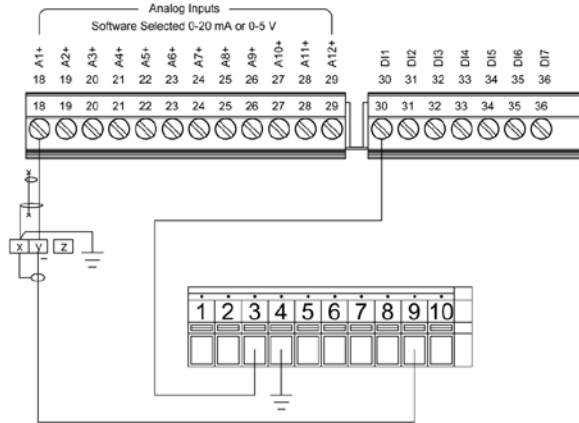
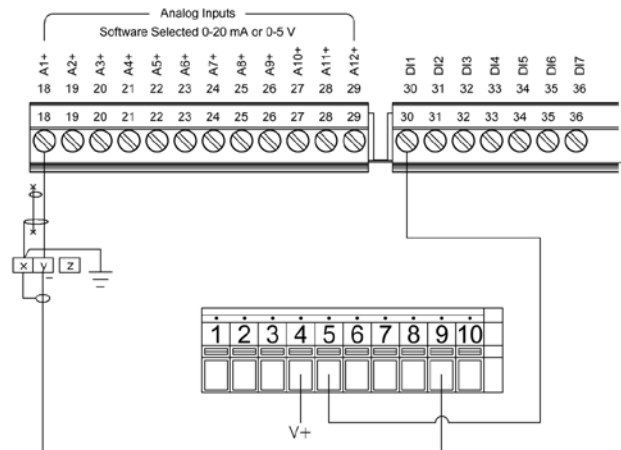
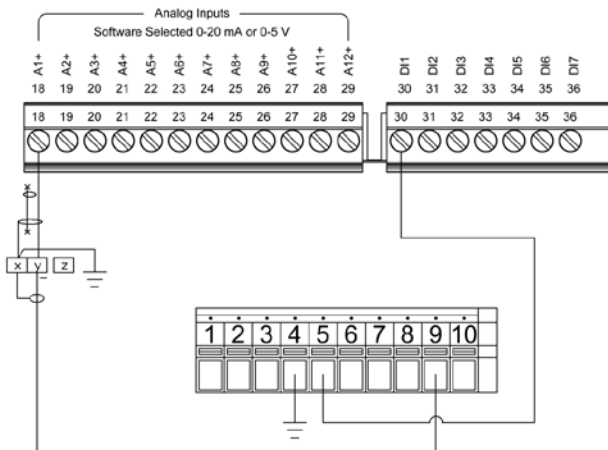

Figure 3 - EVS-2 Hook-up (continued)

EVS-2 Wired to CENTURION C4-1 as Normally Open
 Active Input (V-) Active Input (V+)



EVS-2 Wired to CENTURION C4-1 as Normally Closed
 Active Input (V-) Active Input (V+)



Settings

Setting the Set-Point in Inches Per Second (IPS) Peak

NOTE: The unit must be set per the application upon installation.

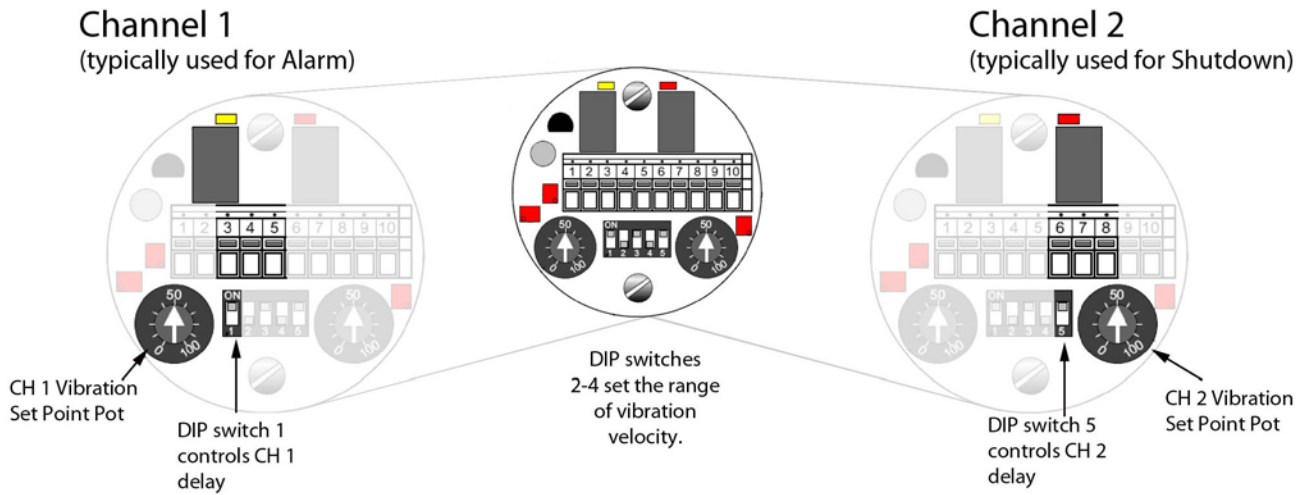

Factory Settings:

- 1.5 IPS
- 1 sec. time delay
- 50% limit value

Figure 4 – EVS-2 Detail for setting IPS and Delay Set-points

Procedure

Refer to the monitored machine recommended setting and mounting information and make appropriate adjustments. To adjust the setpoint, open the Murphy EVS-2 cover and follow these steps:

1. Select the appropriate delay settings and ranges using the DIP switches.
 - A. Time delays for each channel are set to either 1 second or 5 seconds via DIP switch 1 for Channel 1, and DIP switch 5 for Channel 2.
(ON=1 sec; OFF=5 sec)
 - B. Select a range that allows normal vibration and preferred trip points to exist near mid range. Range selection affects both channels. The measurement range in vibration velocity (in/sec peak) is established when:
 - DIP switch 2: ON=0.75 in/sec peak (DIP switches 3, 4=OFF)
 - DIP switch 3: ON=1.50 in/sec peak (DIP switches 2, 4=OFF)
 - DIP switch 4: ON=3.00 in/sec peak (DIP switches 2, 3=OFF)
2. Use a slotted, narrow blade screwdriver to adjust both of the Vibration Set Point potentiometers:
 - To increase the Vibration Set Point, turn the potentiometer clock-wise.
 - To decrease the Vibration Set Point, turn the potentiometer counter clockwise.
3. Make sure that the machine to be monitored is powered on and in normal operation.

Determining & Adjusting the Delay Setpoint (1 or 5 Seconds)

The Delay Setpoint value can define the line between sensitivity and nuisance faults. A 1 second delay allows a potentially catastrophic failure to be detected quickly. A 5 second delay helps prevent normal start-up vibrations from triggering an alarm. An evaluation of these two conditions should be made for each unique installation before setting the Delay Setpoint.

If start-up vibrations exceed the established threshold limits and trigger the alarm at the desired delay set-point, wire the EVS-2 to a "Class B" input timer on a Murphy annunciator or controller. If used with a PLC system, the input can be timed out for startup.

There are two independently adjustable channels. Each channel has its own delay setting.

Useful Vibration Formulas

$V = \pi f D$ $V = 61.44 g/f$ $g = 0.0511 f^2 D$ $g = 0.0162 V/f$ $D = 0.3183 V/f$ $D = 19.57 g/f^2$	D (displacement) = inches peak-to-peak V (velocity)=inches/second=IPS g (acceleration) = 386.1 inches / second ² f (frequency) = RPM/60 rms (root mean squared) = 0.707 x peak peak-to-peak = 2 x peak $\pi = 3.1416$
---	--

Pot Settings

The Vibration Setpoint potentiometers (pots) adjust the level detection based on the scale set in DIP switches 2 through 4. These pots adjust to a percentage of the scale (range) chosen. If 0 to 1.5 IPS is selected as the range, then a pot setting of 50% would cause the EVS-2 to trip at a vibration of 0.75 IPS. Figures 5 and 6 illustrate these pot settings for the EVS-2.

		Range (IPS)		
		0.75	1.5	3.0
Vibration Set Point (% of Selected Range)	0%	0.0	0.0	0.0
	25%	0.2	0.4	0.8
	50%	0.4	0.8	1.5
	75%	0.6	1.1	2.3
	100%	0.8	1.5	3.0

Figure 5

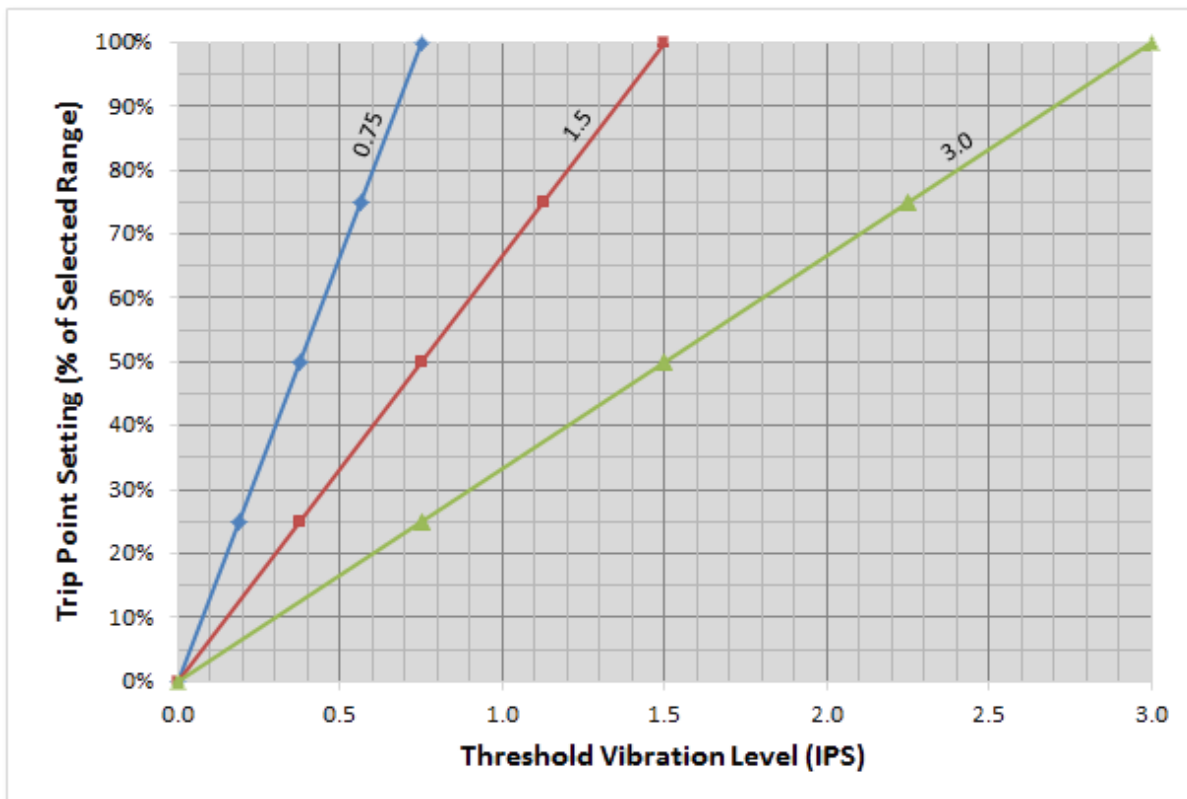

Figure 6

Setting of Alarms

The alarm values may vary considerably, up or down, for different machines. The values chosen will normally be set relative to a baseline value determined from experience for the measurement position or direction for that particular machine.

As shown in Figure 7, it is recommended that the alarm value be set higher than the baseline by an amount equal to 25% of the upper limit for Zone B. If the baseline is low, the alarm should be below Zone C.

Where there is no established baseline (for example with a new machine) the initial alarm setting should be based either on experience with other similar machines or relative to agreed acceptance values.

After a period of time, the steady-state baseline value will be established and the alarm setting should be adjusted accordingly.

Recommended Alarm Settings

The following are guidelines based on industry standards. Actual settings will vary depending on mounting and unit installation. (Note: Refer to the Appendix for recommended settings by specific manufacturers.) Experience with a given installation should be the major factor in deciding the settings.

It is recommended that the alarm value should not normally exceed 1.25 times the upper limit of zone B.

Vibration Limits Based on Class of Equipment Based on ISO 10816-3

	ZONE A = Newly commissioned machines normally fall into this zone.
	ZONE B = Normally considered acceptable for unrestricted long-term operation.
	ZONE C = Normally considered unsatisfactory for long-term continuous operation.
	ZONE D = Normally considered to be of sufficient severity to cause damage to the machine.

RIGID/FLEXIBLE = Categorizes the type of support and mounting.

Vibration ips RMS	CLASS 1		CLASS 2		CLASS 3		CLASS 4		Vibration ips Peak		
	RIGID	FLEXIBLE	RIGID	FLEXIBLE	RIGID	FLEXIBLE	RIGID	FLEXIBLE			
0.58									0.82		
0.43									0.61		
0.28									0.40		
0.18									0.25		
0.14									0.20		
0.11									0.16		
0.09									0.13		
0.06									0.08		
0.03									0.04		
<p>CLASS 1 = Large machines with rated power above 300 kW; electrical machines with shaft height H> 12.4 in. These machines normally have sleeve bearings. the range of operation or nominal speed is relatively broad and ranges from 120 rpm to 15,000 rpm.</p>			<p>CLASS 2 = Medium size machines with a rated power above 15 kW up to and including 30kW; electrical machines with shaft height 6.3 in <H< 12.4 in. These machines normally have rolling element bearings and operation speeds above 600 rpm.</p>			<p>CLASS 3 = Pumps and multivane impeller and with separate driver (centrifugal, mixed flow or axial flow) with rated power above 15 kW. Machines of this group mostly have sleeve or rolling element bearings.</p>			<p>CLASS 4 = Pumps and multivane impeller and with integrated driver (centrifugal, mixed flow or axial flow) with rated power above 15 kW. Machines of this group mostly have sleeve or rolling element bearings.</p>		

Figure 7 – Vibration Limits

Typical Vibration Alarm Settings of Various Installations

THE VALUES LISTED BELOW ARE GUIDELINES ONLY – Actual vibration limits must be related to stress levels, which can be measured with strain gage equipment. In general, if vibration levels are below the guidelines mentioned below, the stress levels are well below the fatigue level of the equipment. If vibration problem is perceived, a spectral analysis should be performed on the unit by a qualified specialist.

Type of Equipment	Velocity (IPS peak)	
	LOW	HIGH
Compressor, Centrifugal	0.2	0.4
Compressor, Reciprocating	0.5	0.7
Conveyors	0.3	0.5
Electric Motors	0.1	0.3
Engines	0.5	0.7
Fans, Blowers	0.2	0.4
Gear Boxes	0.1	0.3
Generator Sets, Electric Driven	0.2	0.3
Generator Sets, Engine Driven	0.5	0.7
Machine Tools (unloaded)	0.05	0.2
Pumps, Centrifugal	0.1	0.3
Pumps, Gear	0.1	0.3
Pumps, Reciprocating	0.5	0.7
Turbines	0.05	0.2

Reciprocating Compressor Vibration Setting Guidelines

THE VALUES LISTED BELOW ARE GUIDELINES ONLY – Cyclical failures generally occur in the range of 10 to 100 cycles. High velocity at high frequency will result in failure at a much greater rate than high velocities at a low frequency. Experience should also be a guideline in determining acceptance limits for a particular compressor package.

Type of Equipment	Velocity (IPS peak)	
	(IPS)	(mm/sec)
Motor Frame	0.3 – 0.5	8 – 12
Compressor Frame	0.2 – 0.3	5 – 8
Compressor Cylinder (outer end)	0.5 – 1.0	12 – 25
Pulsation bottles (outer center)	0.5 – 1.0	12 – 25
Skid Frame (top)	0.1 – 0.3	2.5 – 8
Scrubber (6'-6" elevation)	0.8 – 1.0	20 – 25
Piping (saddles and 12" spans)	0.5 – 0.8	12 – 20
PSV's (top of valves)	0.6 – 0.8	15 - 20

Equipment Manufacturer Recommended Settings

ARIEL: SKID, FRAMES, CYLINDERS (provided by Ariel) MICROLOG CMVA60

SETUP: Velocity ins/sec, zero to peak

If a vibration problem is perceived, a spectral analysis should be performed on the unit by a qualified vibration specialist.

The following chart indicates overall average limits for various models of Ariel equipment. **THESE VALUES ARE GUIDELINES ONLY** - Actual vibration limits must be related to stress levels, which can be measured with strain gage equipment. In general, if vibration levels are below the guidelines mentioned below, the stress levels are well below the fatigue level of the equipment.

Model	JG, A, M, N, P, Q, R, W	JGJ, H, E, T, K	JGC, D, B, V
Skid	<0.10 IPS	<0.15 IPS	<0.20 IPS
Compressor Frame	<0.20 IPS	<0.40 IPS	<0.20 IPS
Compressor Cylinder	<0.45 IPS	<0.80 IPS	<1.0 IPS

Chart effective 10/01/00, Check latest limits on Ariel Web Site.

Other manufacturer's data will be provided as authorized.

Specifications

Performance

Vibration Range: (Customer Selectable DIP Switches): 0.75, 1.50 or 3.00 IPS (peak)

Frequency Range: 5 to 1000 Hz (+/- 5%)

Analog Output (R_{load}): 4 to 20 mA \leq 500 Ω (+/- 5% FS; 1.5 IPS, 21°C) (\pm 10% FS @100Hz; 1.5 IPS, -30 to 85°C)

Raw Signal (R_{load}): 100 mV/g (offset + 5VDC) > 20 k Ω

Environment

Operating Temperature: -22°F to +185°F (-30°C to +85°C)

Storage Temperature: -40°F to +185°F (-40°C to +85°C)

Enclosure Classification: Type 4

CSA C/US

CLASS I, DIV 1, GRP A, B, C, D

CLASS II, DIV1, GRP E, F, G

CLASS III

ATEX

BSi 07ATEX1532458U

Ex d IIC T6, Ex tD A21 T100°C

Electrical

Sensor Type: Accelerometer

Power Required: 20 to 30 VDC

Current Draw: <40 mA

Electrical Connectors: Spring Terminals (26-16 AWG)

Relay

Switch Contact Capacity: 150VAC/125VDC @ 1A

Relay Function: Non-Latching

Threshold Set Point: 10 to 100% of Alarm Set Point

Normally Energized (NE): Fail Safe

Time Delay (Adjust DIP Switch S1 and S5): 1 or 5 seconds

Physical

Housing Material: Aluminum/Epoxy Paint (Red)

Weight: 1.54 lbs. (0.7 kg)

Size (H x W): 4.9 in x 3.9 in (125 x 100 mm)

Mounting Threads: ½" NPT Female (½" NPT Male-to-Male Adapter (86-03-0827) available)

Indicators

Alarm (LED): Yellow

Shutdown (LED): Red

THIS PAGE INTENTIONALLY LEFT BLANK

THIS PAGE INTENTIONALLY LEFT BLANK

In order to consistently bring you the highest quality, full featured products, we reserve the right to change our specifications and designs at any time. MURPHY products and the Murphy logo are registered and/or common law trademarks of Murphy Industries, LLC. This document, including textual matter and illustrations, is copyright protected by Murphy Industries, LLC, with all rights reserved. (c) 2013 Murphy Industries, LLC. A copy of the warranty may be viewed or printed by going to <http://www.fwmurphy.com/warranty>

ENOVATION CONTROLS CORPORATE HEADQUARTERS

5311 S 122ND EAST AVENUE
TULSA, OK 74146

ENOVATION CONTROLS – SAN ANTONIO OFFICE

5757 FARINON DRIVE
SAN ANTONIO, TX 78249

ENOVATION CONTROLS – HOUSTON OFFICE

105 RANDON DYER RD
ROSENBERG, TX 77471

FW MURPHY, LTD. – UNITED KINGDOM

CHURCH ROAD LAVERSTOCK
SALISBURY SP1 1QZ UK

MURPHY ECONTROLS TECHNOLOGIES (HANGZHOU) CO, LTD.

77 23RD STREET
HANGZHOU ECONOMIC & TECHNOLOGICAL DEVELOPMENT AREA
HANGZHOU, ZHEJIANG 310018 CHINA

DOMESTIC SALES & SUPPORT

ECONTROLS PRODUCTS

PHONE: 210 495 9772
FAX: 210 495 9791
EMAIL: INFO@ECONTROLS.COM
WWW.ECONTROLS.COM

MURPHY PRODUCTS

PHONE: 918 317 4100
FAX: 918 317 4266
EMAIL: SALES@FWMURPHY.COM
WWW.FWMURPHY.COM

MURPHY CONTROL SYSTEMS & SERVICES

PHONE: 281 633 4500
FAX: 281 633 4588
EMAIL: CSS-SOLUTIONS@FWMURPHY.COM

MURPHY INDUSTRIAL PANEL DIVISION

PHONE: 918 317 4100
FAX: 918 317 4124
EMAIL: IPDSALES@FWMURPHY.COM

INTERNATIONAL SALES & SUPPORT

UNITED KINGDOM

PHONE: +44 1722 410055
FAX: +44 1722 410088
EMAIL: SALES@FWMURPHY.CO.UK
WWW.FWMURPHY.CO.UK

CHINA

PHONE: +86 571 8788 6060
FAX: +86 571 8684 8878
EMAIL: APSALES@FWMURPHY.COM

LATIN AMERICA & CARIBBEAN

PHONE: 918 317 2500
EMAIL: LASALES@FWMURPHY.COM

SOUTH KOREA

PHONE: +82 70 7951 4100
EMAIL: SKOREASALES@FWMURPHY.COM

INDIA

PHONE: +91 91581 37633
EMAIL: INDIASALES@FWMURPHY.COM

ISO 9001
REGISTERED



USA (TULSA) - ISO 9001:2008 FM 28221
USA (ROSENBERG) - ISO 9001:2008 FM 28221
UK - ISO 9001:2008 FM 29422
CHINA - ISO 9001:2008 FM 52385
Registered Facilities

Printed in the USA