

Series S1501 Selectronic[®] Microcontroller/Annunciator

Installation and Operations Manual

Warranty - A limited warranty on materials and workmanship is given with this FW Murphy product. A copy of the warranty may be viewed or printed by going to <http://www.fwmurphy.com/warranty>



Please read the following information before installing.

BEFORE BEGINNING INSTALLATION OF THIS FW MURPHY PRODUCT:

- Read and follow all installation instructions.
- A visual inspection of this product before installation for any damage during shipping is recommended.
- Disconnect all electrical power to the machine.
- Make sure the machine cannot operate during installation.
- Follow all safety warnings of the machine manufacturer.
- Please contact FW Murphy immediately if you have any questions.

Table of Contents

Product Description	1
Installation	4
Mounting Dimensions.....	4
Typical Hazardous Areas Installation	6
S1501 System - Typical Hook Up	7
Power Supply - Typical Wiring Diagram	10
Operation	11
Operating the S1501 Interface	11
Sequence of Operations - Engine Mode	12
Sequence of Operations - Motor Mode	14
System Set Up Menus	16
Editing System Set Up	17
Troubleshooting	24
Specifications	26
Replacement Parts and Accessories	27

(THIS PAGE INTENTIONALLY LEFT BLANK)

Product Description

The Series S1501 system is a microprocessor based alarm, shutdown and control system with tachometer/hourmeter function. It tells in alphanumeric characters which protective device has signaled an alarm or caused equipment shutdown. Application programming is completed at FW Murphy and can be changed in the field.

The system consists of:

- S1501 Head
- Power Supply - explosion proof
- Terminal Block Assembly, rail mount type, accommodates 32 sensors (two needed for 64 sensor models)
- Flat Ribbon Cable - 36 inch (914 mm) to connect the terminal block to the head

The S1501 is powered from 120 VAC or 12/24 VDC. It is approved for Class I, Div. 1, Groups C & D areas.

S1501 Head

The Head is the brain of the microcontroller system. It contains a microcomputer, an alphanumeric display and keypad for operator access to field adjustable functions and a communication port: RS232 or RS485 (Modbus RTU slave). This port allows for remote control functions such as Start/Stop, Load/Unload, etc., and for access to S1501 data registers.

Alphanumeric Display

The S1501 Head displays each mode of operation. The display is a dot matrix alphanumeric 32-character display arranged in two lines (each with 16 characters). By observing the monitor, the operator can determine the operating status of the control system.

Power Supply

An explosion-proof enclosure designed for Class I, Division 1, Groups C & D hazardous locations contains the supply voltage conditioning circuits, head power supply and the intrinsically safe barriers for isolation between the power supply and the low energy head circuits. The power supply accepts 120 VAC, 50-60 Hz and/or 12-24 VDC input power. 12-24 VDC power can be used as primary power or as a backup source of power when 120 VAC is used.

Control Relays

The power supply has seven control relays to provide form C SPDT outputs for control functions of either the engine or electric motor application.

Terminal Block Assembly

Each sensor input terminal block consists of a 64-position, 32 pair input rail-mount terminal block for interface of panel or field-mounted end devices. For Class I Division 1 areas, end devices must be non-energy storing devices, such as mechanical switches with dry contacts. The terminal block is used for Normally Open sensors (one wire close to ground) and/or Normally Closed sensors (two wires).

Ribbon Cable

A 36 in. (914 mm) flat ribbon cable is required for connection of the S1501 head and the sensor input terminal block. The cable is supplied with two D-sub 37 PIN connectors at each end of the cable.

Power and Control Cable

The S1501 is connected to the power supply via the Power and Control Cable (15-conductor shielded cable, 72 in. [1.81 m] long). The cable is factory sealed on the power supply end and has a 15-pin, D-sub connector on the S1501 Head end.

Sensor Inputs

User-selectable Sensor Input types (Shutdown or Alarm Only) are available for each sensor. The sensor inputs are identified as follows:

Class A: Inputs are operative (armed) all the time.

Class B1: Inputs are enabled after the first preset Start-Run time period.

Class B2: Inputs are enabled after the second preset Start-Run time period.

Class C: Inputs are armed after the fault has been cleared for 2 seconds.

Class P: Armed after the Load Relay has occurred and the process time has expired.

Class ESD: Emergency Stop overrides the test lockout timer.

Permissive Function

This function was designed to monitor prelube pressure input. Terminal 32 of the sensor terminal block is reserved for a permissive prelube input. The pressure signal can be obtained from a pressure switch with normally open or normally closed contacts that indicates whether or not sufficient oil pressure has been reached during prelube. If permissive pressure has not been reached, the system will not allow start-up. If the Permissive Function is not required, install a wire jumper in Terminal 32 and set the Permissive Timer setting at zero.

Opto-Isolated Tach/Run Input

The S1501 features an opto-isolated tach/run input located within the explosion-proof power supply. This special input is used for Run Input Sensing from a CD ignition, Magnetic Pickup, Motor Auxiliary Signal or AC or DC run signals meeting the opto-isolated Tach/Run input specifications (refer to the Specifications section of this manual).

■ **NOTE:** For tachometer sensing, a magnetic pickup is recommended.

Built-In Barrier (within the Power Supply)

The S1501 power supply circuit is isolated from the Head by the intrinsically safe barrier located on the printed circuit board (power supply enclosure) between the power supply output and the power and control cable terminal block.

A fuse barrier mounted inside the Power Supply isolates the power output to the Head. Zener diode shunt barriers isolate the seven control outputs from the Head.

Hourmeter

A hourmeter feature is available for the S1501 to record the engine or motor elapsed running time.

Installation

WARNING: Perform the mounting operation with power source off. The S1501 Head was designed to be mounted within a weatherproof enclosure. It is intended for mounting in a flat panel.

First, cut a square mounting hole of 3-5/8 in. (92 mm) x 3-5/8 in. (92 mm).

Insert the Head from the front side of the panel and install the two mounting clamps, one on each side of the case (see mounting clamp detail).

Secure the unit to the panel by tightening the clamps with a blade type screwdriver.

Mounting Dimensions

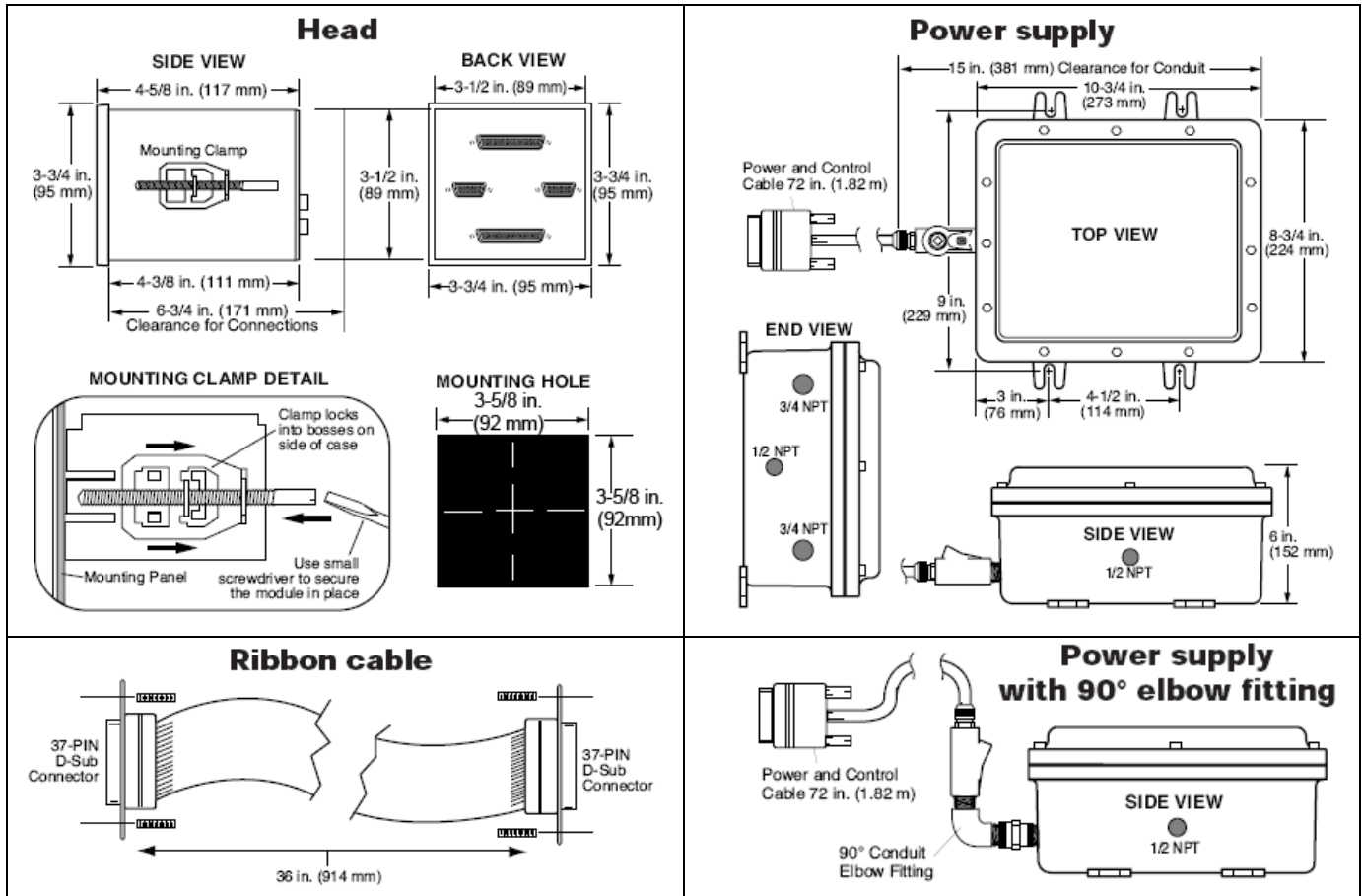

Sensor input terminal block

TERMINAL BLOCK (Rail mount type. 2 terminal blocks required for 64 sensor models)

- * The terminal block has (2) two rail mount clamps for easy panel mounting. □ Mounting rail is **NOT** supplied.
Standard DIN mounting rail models: DIN 46277, EN50035 and EN50022 zinc-plated steel recommended.
Recommended length for the mounting rail: 7 inches (178 mm) minimum.

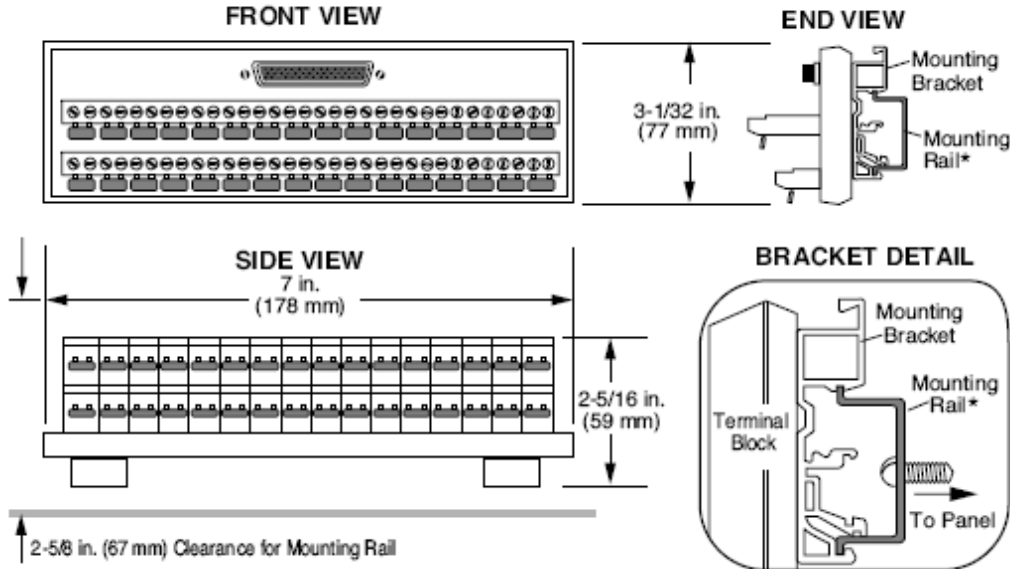

Typical Hazardous Areas Installation

WARNING: FOR HAZARDOUS APPLICATION REQUIREMENTS, THE S1501 COMPLETE SYSTEM MUST BE INSTALLED IN ACCORDANCE WITH THE NATIONAL ELECTRICAL CODE (NEC) CLASS I, DIVISION 1, GROUP D (ARTICLE 504) SPECIFICATIONS. SENSOR INPUT WIRES MUST BE SEPARATED A MINIMUM OF 2 IN. (51 MM) FROM OTHER WIRES. USE OF SENSOR INPUT WIRE TYPE CONDUIT IS RECOMMENDED.

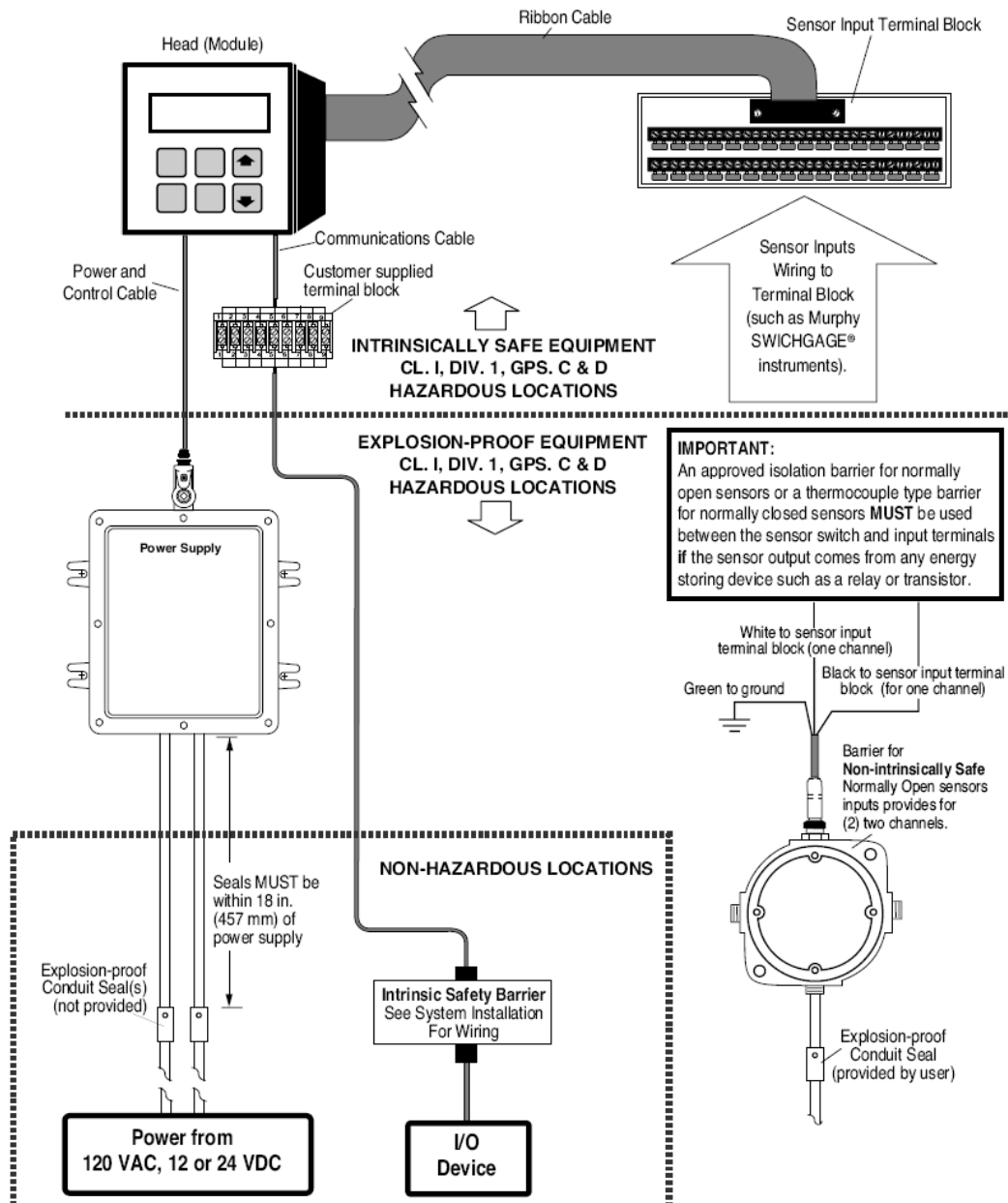

S1501 System – Typical Hook Up

WARNING: PERFORM THE WIRING OPERATION WITH THE POWER SOURCE OFF AND THE AREA MADE NON-HAZARDOUS. MAKE SURE THE VOLTAGE AND CURRENT REQUIREMENTS ARE WITHIN THE S1501 SYSTEM RATINGS. CONDUIT IS REQUIRED TO PROTECT WIRES FROM DAMAGE. REFER TO THE SPECIFIC SYSTEM APPLICATION WIRING DIAGRAM SUPPLIED WITH YOUR UNIT.

Head Connections

- Interconnect the S1501 head and the power supply with the power and control cable. Secure the connector in place by tightening the screws on each side of the connector.
- Repeat step (a.) for the RS232/RS485 serial port (if applicable).
- The sensor input connector(s) from the terminal block(s) plugs into the back of the Head. Secure by tightening the screws on each side of the connector.

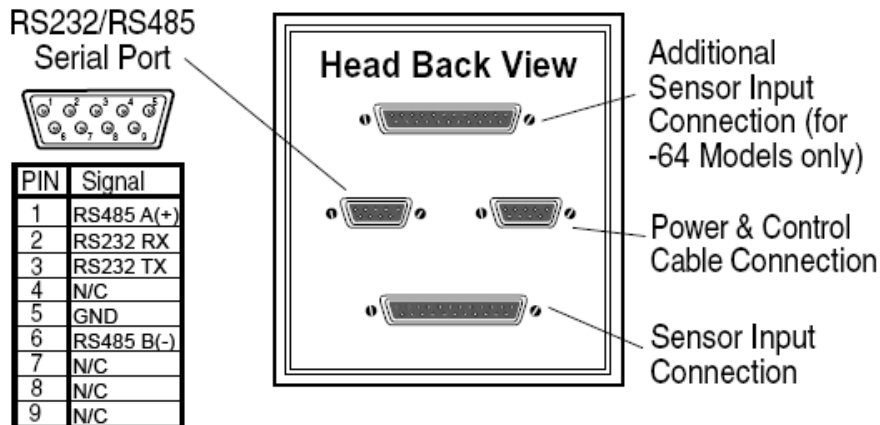

Typical Power Supply Connections

WARNING: Do NOT route the power supply wiring and the sensor input lead wiring in the same conduit.

a. Conduit installation:

- 1) Remove power before opening power supply cover.
- 2) Install one 1/2 in. NPT or two 3/4 in. NPT conduits, from customer end of the Power Supply.

Note: Follow **NEC** guidelines for maximum number of wires in conduit.

- 3) Install an approved explosion-proof seal in the conduit within 18 in. (457 mm) of Power Supply enclosure (seal unused conduit holes).

Important: Green screw above conduit hole (power supply) is to attach equipment ground per **NEC**.

b. Customer Installed Field Wiring: Install wiring to power supply through conduit installed in step 2-a.

- 1) Run wiring from the power source to the S1501 power supply.
- 2) Connect the 120 VAC to the two AC Power Input terminals. Connect equipment ground to green screw (see schematic below).
- 3) Connect the 12 or 24 VDC Positive (+) lead to Power Input terminal 12-24 DC.
- 4) Connect 12 or 24 VDC DC(-) lead to the GND terminal. (See Power Supply Typical Wiring Diagram.)

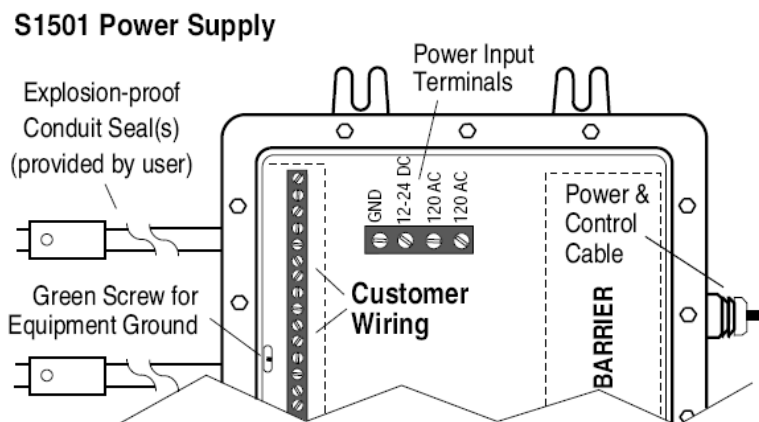

Normally Open Sensor Input Wiring

Wire each normally open sensor on top of the factory-supplied jumper. Loosen the screw and slide the wire lead into the terminal without removing the jumper (either side of jumper).

Normally Closed Sensor Input Wiring

Remove the factory-supplied jumper completely. Connect the two sides of the normally closed sensor to the two terminals of the terminal block.

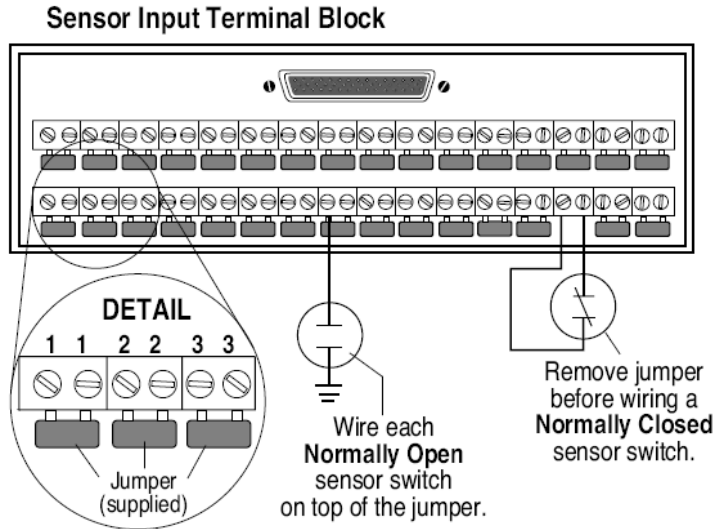

NOTE: Switches connected to the S1501 Sensor Input Terminal Block must be dry contact mechanical switches.

Intrinsically Safe Barrier Wiring

Important (normally open sensor only): Secure area of hazardous conditions before opening barrier cover or operating sensor contacts.

- Run Sensor switches wiring through conduit and isolate from the S1501 terminal block(s) with an explosion-proof barrier.
- For wiring refer to the following typical wiring diagrams.

Intrinsically Safe System Barrier

For normally open or normally closed non-intrinsically safe sensors, use an approved intrinsically safe barrier, and wire according to manufacturer's instructions.

Power Supply - Typical Wiring Diagram

WARNING: Perform the wiring operation with the power source OFF and the area made non-hazardous. Make sure the voltage and current requirements are within the S1501 system ratings. Conduit is required to protect wires from damage. Refer to the specific system application wiring diagram supplied with your unit.

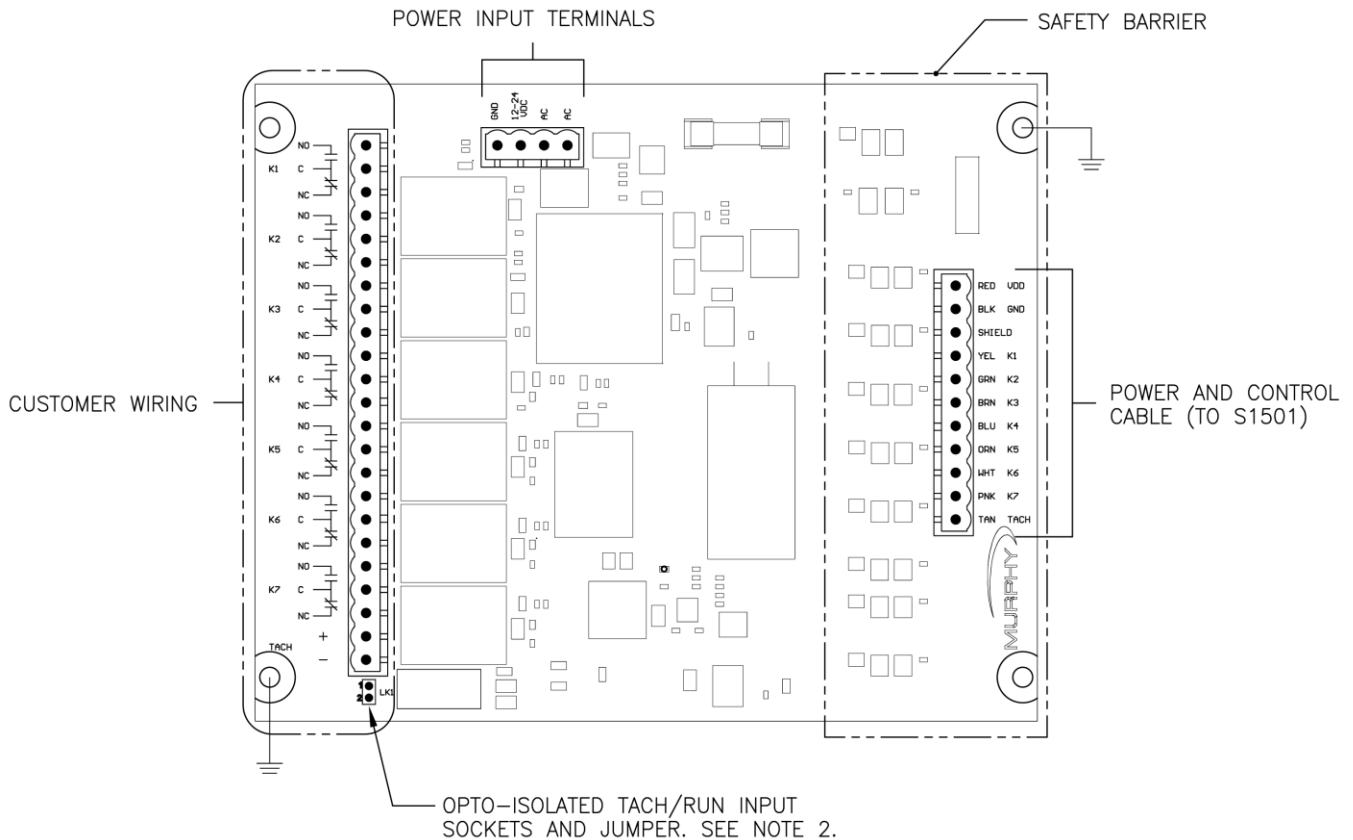

NOTE 1: K-1 thru K-7 are relay outputs form C dry contacts.

D1 thru D8 are LED indicators.

D1= POWER ON;

D2=K1; D3=K2; D4=K3; D5=K4; D6=K5; D7=K6; D8=K7.

NOTE 2: Opto-isolated tach/run input jumper (LK1) is shipped in the installed position. With jumper installed, the input is utilized for a 12/24 VDC motor starter auxiliary contact. With the jumper removed, the input is utilized for a negative or positive ground type CD ignition, 120 VAC motor starter auxiliary contact or a magnetic pickup not exceeding 120 Vrms.

Operation

Operating the S1501 Interface

Use the six membrane keys to scroll through the menus and to make changes to the System timers, Tachometer calibration, Overspeed, Underspeed, Run Hourmeter (ETM) and Sensor Setup.

- ▲ **YES** – key used for scrolling up (increment).
- ▼ **NO** – key used for scrolling down (decrement).
- **RESET** – key used to reset alarms or shutdowns.
- **MODE** – key used for mode and test time modes.
- **START/STOP** – key used for Local mode start and stop signals.
- **ENTER** – key used for entering/confirming set points and exiting menus.

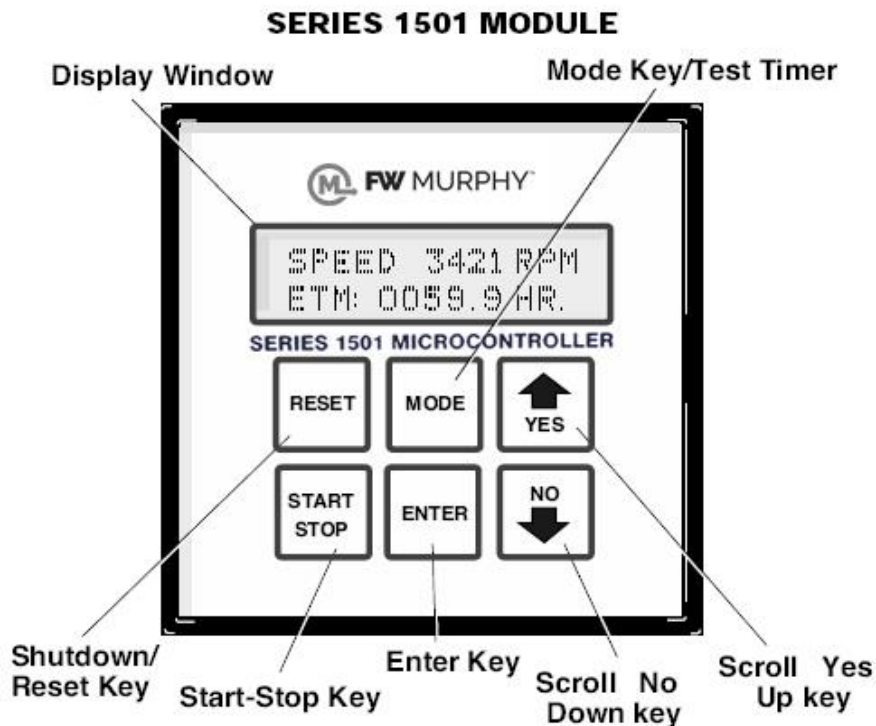

Sequence of Operations - Engine Mode

ENGINE APPLICATION								
EVENT	DISPLAY	RELAY						
		K1	K2	K3	K4	K5	K6	K7
		Lube	Crank	Ign.	Fuel	Load	Alarm	SD
WAITING ON START								
Unit monitors for a valid start signal. Shutdown and Alarm relays are energized. * User can at this time, press the Mode key to modify desired setup tables. Class A inputs are scanned.	Waiting On Start ETM: xxxxx.x hrs	Off	Off	Off	Off	Off	On	On
Start signal received. Unit advances to Prelube cycle.	Waiting On Start ETM: xxxxx.x hrs	Off	Off	Off	On	Off	On	On
If an RPM signal is seen before the Start signal is pressed, a fault occurs.	Unexpected Engine Start!	Off	Off	Off	On	Off	Off	Off
PRELUBE CYCLE								
Prelube cycle begins. Permissive timer starts. Lube relay energized.	LUBE CYCLE... Permissive x:xx	On	Off	Off	Off	Off	On	On
Permissive time expires before Permissive signal* seen closed. Fault occurs. Lube relay is de-energized.	Permissive Failure	Off	Off	Off	Off	Off	Off	Off
Permissive signal closed. Prelube Cycle timer started.	LUBE CYCLE... Prelube x:xx	On	Off	Off	Off	Off	On	On
Prelube Cycle timer times down to zero. Unit advances to Crank cycle.	LUBE CYCLE... Prelube :00	On	Off	Off	Off	Off	On	On
CRANK CYCLE								
Crank Relay energizes. If the Run Delay Preset is > 0, the controller will wait for a Crank RPM permissive to proceed. If set to 0, this cycle is skipped.	CRANK PERMISS... Run Delay x:xx	On	On	Off	Off	Off	On	On
Run Delay time expires before RPM > 10 is seen. Fault occurs.	Engine Failure To Crank!	Off	Off	Off	Off	Off	Off	Off
RPM > 10 is seen, or Crank Permissive cycle skipped. Cranking continues with purge timer started at preset time.	CRANK CYCLE... Purge :xx	On	On	Off	Off	Off	On	On
Purge delay expires. Ignition relay is energized. Fuel On delay is started.	CRANK CYCLE... Fuel Delay :xx	On	On	On	Off	Off	On	On
Fuel On delay expires. Fuel relay energized. Crank timer started. The Controller will monitor for a Crank Disconnect RPM to advance to the Run Cycle.	CRANK CYCLE... Crank :xx	On	On	On	On	Off	On	On
Crank timer expires before disconnect speed is reached. Unit goes into Rest cycle. Crank, Ignition, and Fuel relays are de-energized. When the Rest expires the Crank Cycle will repeat.	CRANK CYCLE... Rest :xx	On	Off	Off	Off	Off	On	On
All crank attempts exhausted. Crank timer expires. Disconnect speed not reached. Overcrank condition occurs. All relays de-energized.	Overcrank Shutdown!	Off	Off	Off	Off	Off	Off	Off

		K1	K2	K3	K4	K5	K6	K7
		Lube	Crank	Ign.	Fuel	Load	ALM	SD
RUN CYCLE								
Crank Disconnect RPM reached. Crank relay de-energized. Class B1 Lockout, B2 Lockout and Load timers started. Class C shutdowns are allowed to arm.	Speed: xxxrpm Class-B1 x:xx	Off	Off	On	On	Off	On	On
Class B1 and B2 Lockout timers expire. Elapsed time displayed. Unit monitors for stop condition.	Speed: xxxrpm ETM: xxxxx.x hrs	Off	Off	On	On	Off	On	On
Load timer expires. Load relay energized. Process Lockout timer starts. When this timer expires, Class P shutdowns will be armed. User can press the Mode key to initiate the Test timer and test sensor inputs.	Speed: xxxrpm Test Timer 5:00	Off	Off	On	On	On	On	On
IDLE CYCLE								
Stop signal is seen. Load relay is de-energized. Class P shutdowns are disarmed. Idle timer is started.	Speed: xxxrpm Idle x:xx	Off	Off	On	On	Off	On	On
ALARM FAULT								
Alarm only input faulted. Alarm relay de-energized. Fault alternately displayed with previous message displaying the speed and run hours.	Low Coolant Level	Off	Off	On	On	On	Off	On
S1501 Reset key pressed. Alarm relay is picked up. Unit continues to scans for fault or stop condition.	Speed: xxxrpm ETM: xxxxx.x hrs	Off	Off	On	On	On	On	On
FAULT SHUTDOWN								
Unit receives a fault at sensor #4 for instance. The Fuel Valve, Alarm and Shutdown relays are de-energized.	Speed: xxxrpm Ign. Gnd. :xx	Off	Off	On	Off	Off	Off	Off
Ignition ground delay expires. Ignition relay de-energized. Postlube cycle begins. Lube relay energized.	LUBE CYCLE... Postlube x:xx	On	Off	Off	Off	Off	Off	Off
Postlube expires. Lube relay de-energized. Fault is displayed.	Low Compressor Oil Pressure	Off	Off	Off	Off	Off	Off	Off
S1501 Mode key pressed. Shutdown type displayed.	Sensor Input #04 Class B1,Shutdown	Off	Off	Off	Off	Off	Off	Off
S1501 Reset key pressed. Unit waiting on start input.	Waiting On Start ETM: xxxxx.x hrs	Off	Off	Off	Off	Off	On	On
NORMAL STOP (AFTER IDLE CYCLE)								
Stop signal received and idle timer expired. Ignition ground delay begins. Fuel Valve relay de-energized.	Speed: xxxrpm Ign. Gnd. :xx	Off	Off	On	Off	Off	On	On
Ignition ground delay expires. Ignition relay de-energized. Postlube cycle begins. Lube relay energized.	LUBE CYCLE... Postlube x:xx	On	Off	Off	Off	Off	On	On
Postlube cycle timer expires. The Lube relay is de-energized. Unit returns to Waiting on Start.	Waiting On Start ETM: xxxxx.x hrs	Off	Off	Off	Off	Off	On	On

Sequence of Operations - Motor Mode

ELECTRIC MOTOR APPLICATION								
EVENT	DISPLAY	RELAY						
		K1	K2	K3	K4	K5	K6	K7
		Lube	Not Used	Motor	Cooler	Load	Alarm	SD
WAITING ON START								
Unit monitors for a valid start signal. Shutdown and Alarm relays are energized. * User can at this time, press the Mode key to modify desired setup tables. Class A inputs are scanned.	Waiting On Start ETM: xxxxx.x hrs	Off	Off	Off	Off	Off	On	On
Start signal received. Unit advances to Prelube cycle.	Waiting On Start ETM: xxxxx.x hrs	Off	Off	Off	On	Off	On	On
PRELUBE CYCLE								
Prelube cycle begins. Permissive timer starts. Lube relay energized.	LUBE CYCLE... Permissive x:xx	On	Off	Off	Off	Off	On	On
Permissive time expires before Permissive signal* seen closed. Fault occurs. Lube relay is de-energized.	Permissive Failure	Off	Off	Off	Off	Off	Off	Off
Permissive signal closed. Prelube Cycle timer started.	LUBE CYCLE... Prelube x:xx	On	Off	Off	Off	Off	On	On
Prelube Cycle timer times down to zero. Unit advances to Wait On Run cycle.	LUBE CYCLE... Prelube :00	On	Off	Off	Off	Off	On	On
WAIT ON RUN CYCLE								
Motor Relay energizes. Run delay and Cooler On Delays begin timing. The controller monitors for an electric motor auxiliary contact run confirmation.	Waiting On Run Run Delay x:xx	On	Off	On	Off	Off	On	On
Run Signal not received before the delay expires, Fault occurs. All relays de-energize.	Motor Starter Failure!	Off	Off	Off	Off	Off	Off	Off
S1501 Reset key pressed. Unit waiting on start input.	Waiting On Start ETM: xxxxx.x hrs	Off	Off	Off	Off	Off	On	On
RUN CYCLE								
Motor auxiliary contact seen closed. Lube relay de-energizes. Class B1 Lockout, B2 Lockout and Load timers started. Class C shutdowns are allowed to arm.	Motor Running... Class-B1 x:xx	Off	Off	On	On	Off	On	On
Cooler On delay expires. The Cooler relay energizes.	Motor Running... Class-B1 x:xx	Off	Off	On	On	Off	On	On
Class B1 and B2 Lockout timers expire. Elapsed time displayed. Unit monitors for stop condition.	Motor Running... ETM: xxxxx.x hrs	Off	Off	On	On	Off	On	On
Load timer expires. Load relay energized. Process Lockout timer starts. When this timer expires, Class P shutdowns will be armed. User can press the Mode key to initiate the Test timer and test sensor inputs.	Motor Running... Test Timer 5:00	Off	Off	On	On	On	On	On
IDLE CYCLE (COOLDOWN)								
Stop signal is seen. Load relay is de-energized. Class P shutdowns are disarmed. Idle timer is started.	Motor Running... Idle x:xx	Off	Off	On	On	Off	On	On
ALARM FAULT								
Alarm only input faulted. Alarm relay de-energized. Fault alternately displayed with previous message displaying the speed and run hours.	Low Coolant Level	Off	Off	On	On	On	Off	On
S1501 Reset key pressed. Alarm relay is picked up. Unit continues to scans for fault or stop condition.	Motor Running... ETM: xxxxx.x hrs	Off	Off	On	On	On	On	On

		K1	K2	K3	K4	K5	K6	K7
		Lube	Not Used	Motor	Cooler	Load	Alarm	SD
FAULT SHUTDOWN								
Unit receives a fault at sensor #4 for instance. Motor, Cooler, Load, Alarm and Shutdown relays are de-energized. Postlube cycle begins. Lube Relay energized.	LUBE CYCLE... Postlube x:xx	On	Off	Off	Off	Off	Off	Off
Postlube expires. Lube relay de-energized. Fault is displayed.	Low Compressor Oil Pressure	Off	Off	Off	Off	Off	Off	Off
S1501 Mode key pressed. Shutdown type displayed.	Sensor Input #04 Class B1,Shutdown	Off	Off	Off	Off	Off	Off	Off
S1501 Reset key pressed. Unit waiting on start input.	Waiting On Start ETM: xxxxx.x hrs	Off	Off	Off	Off	Off	On	On
NORMAL STOP (AFTER IDLE-COOLDOWN CYCLE)								
Stop signal received and idle timer expired. Motor and Cooler relays de-energized. Postlube cycle begins. Lube relay energized	LUBE CYCLE... Postlube x:xx	On	Off	Off	Off	Off	On	On
Postlube cycle timer expires. The Lube relay is de-energized. Unit returns to Waiting on Start.	Waiting On Start ETM: xxxxx.x hrs	Off	Off	Off	Off	Off	On	On

System Set Up Menus

While the S1501 displays Waiting On Start, pressing the MODE key will access the SYSTEM SET UP menu. The following options are available:

- Timer Set Up
- Tach/Crank Set Up
- ETM Set Up
- Sensor Set Up

Timer Set Up - This setup screen allows you to preset the system timers. Zeroing out a function's timer will bypass that particular function.

Advanced Set Ups (password protected screens)

The following Set Ups are available only under ADVANCED SETUP mode.

Tach/Crank Set Up - This setup screen allows you to calibrate the internal tachometer with pulses per revolution and set the Overspeed, Underspeed, Crank Attempt set points and Crank Disconnect.

ETM Set Up - This setup screen allows you to preset the Elapsed Time Meter (ETM).

Sensor Set Up - This setup screen allows you to edit shutdown or alarm messages and also to edit the input sensor class (A, B1, B2, C, P or ESD) and the action (Alarm only or Shutdown).

NOTE: Communications will be disabled while using the keypad to access the System Set Up menu.

Editing System Set Up

Timer Set Up Menu

There are a number of Timers that the S1501 system uses to carry out the start/stop sequencing. With all shutdowns cleared and the S1501 at the Waiting On Start prompt, press the ■ MODE key to gain access to the Timer Set Up Menu.

TIMER SET UP
Permissive x:xx

This displays the timer preset in MM:SS format. Press ▲ UP/YES or ▼ DOWN/NO keys to increase or decrease the time. Press ■ RESET to zero the timer. Press ■ ENTER to accept and save the setting and advance to the next timer.

Repeat the procedure to preset all available timers.

NOTE: To bypass a particular function, zero out the corresponding timer. For example, to bypass Prelube, zero out the Prelube timer.

Permissive x:xx

During the Prelube cycle, this is the preset time by which the Permissive input must be seen closed (NC system) or ungrounded (NO system). If the Permissive input is not satisfied when the timer expires, a Permissive Failure fault shutdown will occur.

NOTE: Terminal 32 is dedicated for the Permissive Pressure Input. To bypass this function, install a jumper at terminal 32.

Prelube x:xx

During the Prelube cycle, this is the preset time for which the Lube relay remains energized after the Permissive input is satisfied, prior to starting.

Purge Delay x:xx

Timer to purge excess fuel out of the engine on a crank attempt. The Crank relay is energized with the fuel valve relay de-energized and the ignition relay de-energized.

Fuel Delay x:xx

Timer to delay energizing the fuel valve relay on a crank attempt to burn unspent fuel. The ignition relay is energized during this time.

Crank x:xx

Time duration for the crank attempt after energizing the crank, ignition and fuel valve relays.

Rest x:xx

Time duration for the Crank Rest period after the Crank period expires. However, if the specified number of Crank attempts is exhausted, an Overcrank Shutdown occurs.

Run Delay x:xx

In Electric Motor applications (Pulses/rev = 0), this is the timer to gain the Motor Starter Auxiliary Run signal, after energizing the motor relay. If this signal is not seen before this timer expires, a Motor Starter Failure shutdown will occur.

In Engine applications (Pulses/rev > 0), this is the timer to gain RPM reading > 10 before the Ignition and Fuel relays are energized. If this signal is not seen before this timer expires, an Engine Failure To Crank shutdown will occur. If set to 0, this RPM permissive is ignored.

Class-B1 x:xx

This timer locks out sensor inputs configured as Class B1 on startup.

Class-B2 x:xx

This timer locks out sensor inputs configured as Class B2 on startup.

Load x:xx

This timer delays energizing of the Load relay after starting and is typically used as a warmup time.

Process x:xx

This timer locks out sensor inputs configured as class P after energizing the Load relay. This is typically used for Process alarms and shutdowns which do not clear until the unit has loaded.

Idle x:xx

This timer determines the length of time the system will run after de-energizing the Load relay after a stop signal is received. This is typically used for a Cooldown time period for the equipment.

Ign. Gnd. x:xx

In Engine applications (Pulses/rev > 0), this is the delay between de-energizing the fuel valve relay and de-energizing the ignition relay. This allows remaining fuel in the line to be burned off prior to disabling the ignition system.

Postlube x:xx

After a stop or shutdown fault (non-ESD), this is the time for which the Lube relay will be energized for a postlube cycle.

Cooler Dly x:xx

In Electric Motor applications (Pulses/rev = 0), this timer delays energizing the cooler relay after energizing the motor relay to reduce inrush current imposed on the power source for the AC motors.

Advanced Set Up Menu

To calibrate the Tachometer and Elapsed Time Meter, select Crank attempts, Modbus RTU address and modify sensor input information, a password protected setup mode is available. After the Timer Setup is complete, the LCD will read...

```
ADVANCED SETUP
Password      XXXX
```

To Exit Setup quickly without entering the Advanced Setup at this point, press ■ RESET and ■ ENTER at the same time.

The first X will be blinking. To enter the password use the ▲ UP/YES or ▼ DOWN/NO keys to scroll through the characters. Press ■ RESET and ■ MODE to scroll between characters. When the correct password is entered, press ■ ENTER to acknowledge. The following screen will be briefly displayed:

```
ADVANCED SETUP
PASSWORD OK!
```

If password is incorrect the screen will be the following:

```
ADVANCED SETUP
PASSWORD ERROR!
```

User will again be prompted to enter correct password. After three unsuccessful entries, the Advanced Set up is aborted and screen will return to Waiting On Start.

```
ADVANCED SETUP
Pulses/rev    xx
```

Press ▲ UP/YES or ▼ DOWN/NO keys to increase or decrease the value. Press ■ ENTER to accept and save the setting and advance to the next setting.

```
Pulses/rev    xx
```

To calibrate the internal tachometer, enter the pulses per revolution of the engine. **To set the controller for an electric motor logic sequence, this setting must be set to 0.**

Enter either the number of teeth in the fly wheel if using a Magnetic Pickup, or use the following equation if using the Ignition input:

$$\text{Pulses} = 2 * \text{Cylinders} \backslash \text{Cycles}$$

For instance, for an 8 cylinder, 4 cycle engine,

$$\text{Pulses} = 2 * 8 \backslash 4 = 4$$

```
Attempts      x
```

Engine sequence only-This is the number of allowable engine crank cycles before an Overcrank Shutdown occurs.

```
Disconnect    xxxx
```

Engine sequence only-This is the RPM at which the crank relay de-energized and the engine is considered running.

Overspeed xxxx

Engine sequence only-This is the excessive speed RPM at which the S1501 signals an internal Overspeed Shutdown.

Underspeed xxxx

Engine sequence only-This is the low speed RPM at which the S1501 signals an internal Underspeed Shutdown. This is not armed until the Class B1 timer expires.

ETM 1k Hr xx

Preset the Elapsed Time Hours thousands hours or use the RESET button to zero it.

ETM 100 Hr xx

Preset the Elapsed Time Hours hundred hours or use the RESET button to zero it.

ETM Secs Hr xx

Preset the Elapsed Time Hours seconds or use the RESET button to zero it.

Sensor Set Up

The S1501 system allows you to edit the Shutdown Message, Class Type and Shutdown Action (Shutdown Alarm or Alarm only) for each Sensor Input. Class Type are defined as follows:

Class A, Shutdown
Class B1, Shutdown
Class B2, Shutdown
Class C, Shutdown
Class P, Shutdown
ESD, Shutdown
Class A, Alarm
Class B1, Alarm
Class B2, Alarm
Class C, Alarm
Class P, Alarm
Ignore Point

Press ▲ UP/YES or ▼ DOWN/NO keys to select the input to modify. Select INPUT #0 to exit.

Press ■■ ENTER once the desired input is chosen, and the corresponding shutdown message will be displayed.

LOW OIL
PRESSURE

With the first character blinking you may change the character by pressing the ▲▲ UP/YES or ▼ DOWN/NO keys to scroll through available characters. Press ■■ MODE to move forward on character or ■■ RESET to move backward. When the shutdown modification is completed, press ■■■ ENTER to save the new message. The Sensor Class Type and function will now be displayed, for example:

SHUTDOWN TYPE
CLASS A SHUTDOWN

To change the Class Type and function, use the ▲▲ UP/YES or ▼ DOWN/NO keys until the desired combination of Class and Function is reached. Press the ■■■ ENTER key to save and return to the Setup screen. Repeat as above for all Sensors Inputs and Messages to be edited.

Start/Stop Configuration

The S1501 system can be configured for Local and/or Remote Start-Stop. Start-Stop is configured via terminal block inputs TB30 (local), TB31 (Remote).

Keypad Start

Jumper installed in TB30. A valid sequence occurs when the ■ START/STOP key is pressed. Likewise, while running, a valid stop sequence occurs when the ■ START/STOP key is pressed.

NOTE: A valid stop occurs when the ■ START/STOP key is pressed Regardless of the Start-Stop mode.

Local-Off-Remote (L-O-R) Switch

L-O-R switch installed across TB30 (Local) and TB31 (Remote). A valid sequence occurs when the L-O-R switch is placed in the Local position and the Start-Stop key is pressed OR the L-O-R is placed in the Remote position and the Remote Start signal is seen. A valid Stop occurs when the L-O-R switch is placed in the OFF position OR in the Remote position and a Remote Stop is seen.

Remote Start-Stop

Jumper installed in TB31. A valid sequence occurs when a Remote Start signal is seen. Likewise, a valid stop occurs when the Remote Stop signal is seen.

Maintain Start

Jumper installed in TB31. A valid sequence occurs when the Maintain Start signal is seen. Likewise, a valid stop occurs when the Maintain Start signal is lost.

Typical Start/Stop Wiring

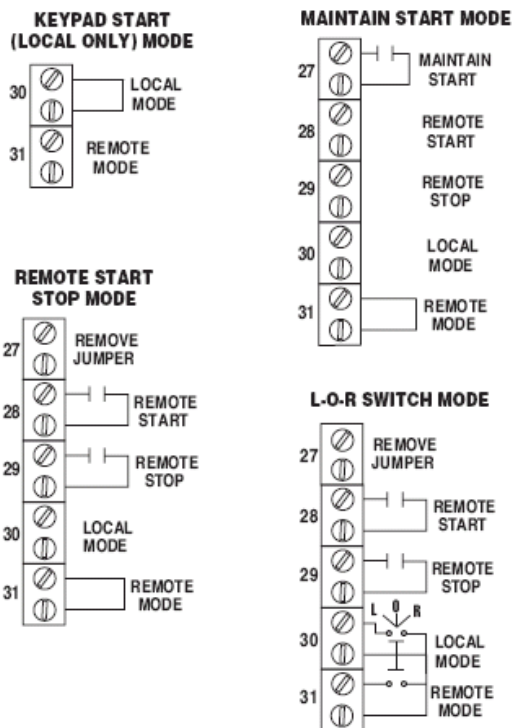

Modbus Start/Stop and Reset

The S1501 system can be started and stopped remotely through the Modbus communications port (RS232/RS485 serial port). Writing a 1 to the start/stop register (40010) will initiate a start. Writing a 0 to the start /stop register will initiate a stop. Writing 0 to the shutdown status register (40004) will cause a reset.

Modbus Integer Holding Registers

Address	Access	Description
40001	Read	RPM
40002	Read	Class B1 Timer Accumulator Seconds
40003	Read	ETM (Elapsed Run Time Meter) Hundred Hours (0 – 999)
40004	Read/ Write	<p><i>Shutdown Status Enumeration/Remote Modbus Reset (0=OK, or terminal block number of Shutdown event...writable to 0 for Modbus Reset)</i></p> <p><i>System Internal shutdowns:</i></p> <p><i>68 = Engine Overspeed (engine applications)</i></p> <p><i>70 = Engine Underspeed (engine applications)</i></p> <p><i>72 = Overcrank (engine applications)</i></p> <p><i>74 = Permissive Failure</i></p> <p><i>76 = Motor Starter Failure (motor applications)</i></p> <p><i>78 = Local Stop (by keypad)</i></p> <p><i>80 = Unexpected Engine Start (engine applications)</i></p> <p><i>86 = Loss of Tach Signal (engine applications)</i></p> <p><i>88 = Loss of Run Signal (motor applications)</i></p> <p><i>96 = Engine Failure To Crank (engine applications)</i></p>
40005	Read	Relay Output Status (bitmapped Bit 0=K1 ... Bit 1=K2, etc)
40006	Read	Inputs TB01-16 Status (bitmapped Bit 0=TB1 ... Bit 1=TB2, etc)
40007	Read	Inputs TB17-32 Status (bitmapped Bit 0=TB17 ... Bit 1=TB18, etc)
40008	Read	Inputs TB33-48 Status (bitmapped Bit 0=TB33 ... Bit 1=TB34, etc)
40009	Read	Inputs TB49-64 Status (bitmapped Bit 0=TB49 ... Bit 1=TB50, etc)
40010	Read/ Write	<i>Start/Stop Register (writable for remote commands if Remote Mode on TB29 is closed and remote maintained start digital input TB27 not used. It is active for a write of 0 at all times to allow remote stopping, until a start signal is received again)</i>
40011	Read/ Write	<i>40011 = Load/Unload Register (writable for resetting the Load relay after the LOAD relay has been energized by the program, and setting it again if it has been reset through Modbus. This resets and restarts the Process delay, at the same time as the Load relay is reset and set)</i>
40012	Read	ETM (Elapsed Run Time Meter) Thousand Hours (0 – 99)
40013	Read	<p>State Bitmap</p> <ul style="list-style-type: none"> Bit 0 = WAITING ON START Bit 1 = PERMISSIVE Bit 2 = PRELUBE Bit 3 = CRANK PERMISSIVE Bit 4 = PURGE Bit 5 = FUEL DELAY Bit 6 = CRANK Bit 7 = REST Bit 8 = RUN DELAY Bit 9 = LOAD DELAY (WARMUP) Bit 10 = LOADED Bit 11 = UNLOADED Bit 12 = IDLE (COOLDOWN) Bit 13 = IGN GND DELAY Bit 14 = POSTLUBE Bit 15 = SHUTDOWN
40014	Read	Alarm Status Enumeration (0=OK, or terminal block number of last alarm event)

Troubleshooting

WARNING: Do NOT open power supply until operations have been shutdown and area has been rendered non-hazardous. Do NOT run sensor wires in conduit with any other wire. Do NOT apply voltage to any annunciator input terminals. Do NOT bundle sensor wires with any other wiring. Make sure the voltage and current requirements are within the S1501 system ratings.

Before going through the checklist below, refer to the connections and operation procedures. Also check your system wiring schematic.

If any problems persist after you have made these checks, consult your nearest FW Murphy facility.

Symptom: No display

- Check that the Power & Control cable is firmly connected to the back of the S1501. Check for damaged or broken wire.
- Check for power failure or power input shutdown.
- Check the 200 mA fuse within the S1501 power supply and replace if necessary.

NOTE: If after all of the above has been accomplished and there is still no display, return the S1501 to FW Murphy for repair or replacement.

Symptom: Engine fails to start (Sensor switch fault display cannot be cleared.)

- Check that the Power & Control cable is firmly connected to the back of the S1501. Check for damaged or broken wire.
- Check that the sensor input cable connector (ribbon cable) is properly connected to the back of the S1501.
- Verify that the LED lights (within the power supply box) are lit indicating relays are functioning.
- Check that the wire leads on the terminal block under the Safety Barrier cover are connected and tight. (See drawing at right.)
- Measure the voltage between terminals 1 and 2 on the terminal block under the Safety Barrier cover (voltage should read between 5 - 6 VDC). Do this with the S1501 connected to the power supply and with it disconnected. There should not be more than a 0.5 V difference between the readings with the S1501 connected and not connected.

- Check sensor wires with an ohmmeter and meg or high potential test only with wires disconnected from sensor terminal block.

NOTE: If shutdowns still result, contact your nearest FW Murphy representative/dealer.

S1501 HEAD (back view)

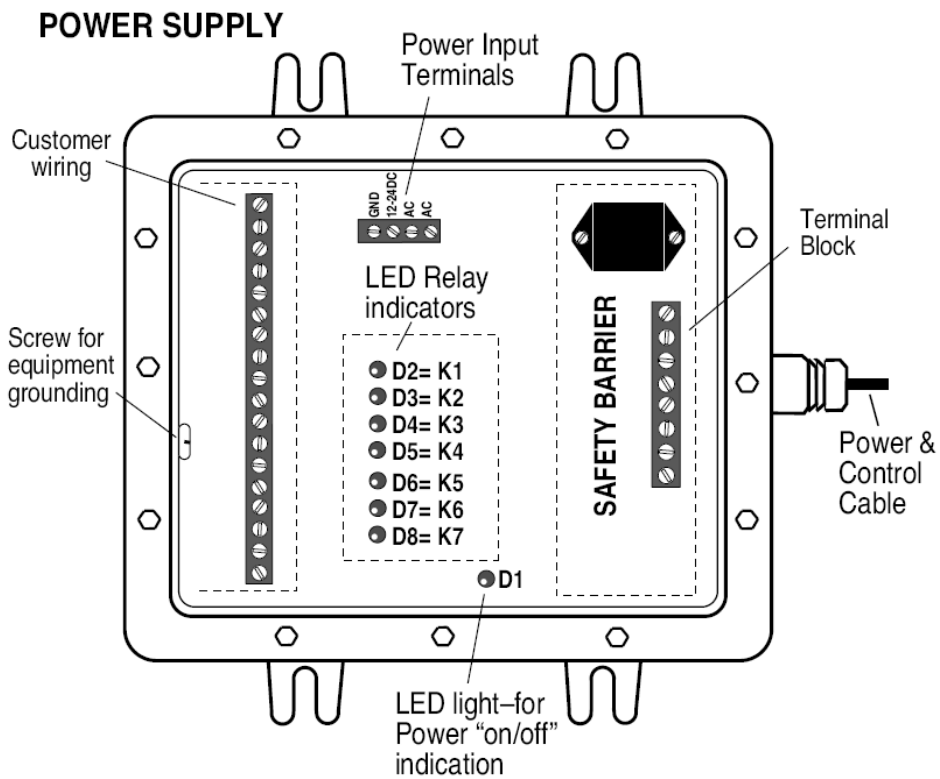
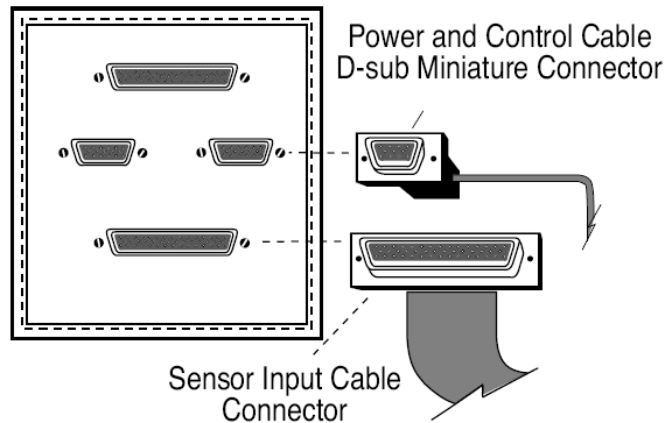

Specifications

Power Consumption

- 120 VAC (7.5 VA)
- 12 VDC (3.5 watts)
- 24 VDC (3.5 watts)

Sensor Inputs

32 or 64 N.O. and/or N.C. inputs such as FW Murphy gauge instruments.

Field selectable as a Class A, B1, B2, C, P or ESD for shutdown, alarm or control function.

NOTE: Sensor inputs 27 through 32 reserved for control functions.

Outputs

7-SPDT relay outputs, 5 A, 1/16 HP, 125/250 VAC/ 1 A, 30 VDC

NOTE: For hazardous areas, an approved isolation barrier must be used between sensor switch and input terminals if the sensor output comes from any energy storing device such as a relay or transistor.

Adjustable Time Delays

- Permissive
- Prelube
- Purge
- Fuel
- Crank
- Run
- Class B1 Lockout
- Class B2 Lockout
- Process Lockout
- Idle/Cooldown
- Ignition Ground
- Postlube
- Cooler

Sensor Inputs Terminal Block

Rail mount DIN type; 32 terminals, screw type

Opto-Isolated Tach/Run Input

Magnetic pickup, 4.5 to 120 Vrms, 0-10 kHz. CD ignition, positive or negative ground, 100 to 300 VDC, 3-666 Hz. 12 to 125 VDC or 120 Vrms, 50/60 Hz may be used for run signals.

Operating Temperatures: 32 to 122°F (0 to 50°C)

Storage Temperatures: -4 to 158°F (-20 to 70°C)

Case: ABS plastic, 1/4 DIN (90 x 90 mm)

Communications

Factory configured for RS232; field-selectable for RS485.

Alphanumeric Display

2 lines, each line with 16 characters (32 characters total)

Power Supply Enclosure

Explosion-proof, Class I, Division 1. Intrinsically safe barrier built into the power supply, 120 VAC with 7 form C relay outputs for the following functions (with standard S1501):

- Lube
- Crank
- Ignition/Motor
- Fuel/Cooler
- Load
- Alarm
- Shutdown

Replacement Parts and Accessories

To order the S1501 system, specify the model number for each individual component and accessory:

S1501H-32-2	Head with RS232/RS485 port for 32 sensors
S1501H-64-2	Head with RS232/RS485 port for 64 sensors
S1501CH-32-2	Head w/custom* program, RS232/RS485 port, 32 sensors
S1501CH-64-2	Head w/custom* program, RS232/RS485 port, 64 sensors
S1500TB32	Terminal Block only**
S1500CA36	Ribbon Cable Assembly**
S1501PS-120	120 VAC, 12 or 24 VDC Power Supply

Accessories:

S1501PCA72	Power and Control Cable Assembly, 72 in. (1.8 m) long
S1501PS-120-E	Power Supply with 90° Conduit Elbow fitting
S1501PS-120-LC	Power Supply less case
S1501PS-120-LC-	AMOT KIT Power Supply less case, AMOT Retrofit K

Approximate Shipping Weights / Dimensions

S1501 complete system:

28 lb. (12.7 kg) / 20 x 14 x 12.5 in. (508 x 356 x 218 mm)

S1501H-32-2; S1501H-64-2; S1501CH-32-2; S1501CH-64-2:

2 lb. (0.907 kg) / 6 x 6 x 6 in. (152 x 152 x 152 mm)

S1500TB32:

2 lb. (0.907 kg) / 12 x 7 x 4 in. (305 x 178 x 102 mm)

S1500CA36; S1501PCA72:

2 lb. (0.907 kg) / 6 x 6 x 6 in. (152 x 152 x 152 mm)

S1501PS-120-LC:

3 lb. (1.36 kg) / 12 x 7 x 4 in. (305 x 178 x 102 mm)

S1501PS-120 and S1501PS-120-E:

22 lb. (9.98 kg) / 17 x 10 x 9.75 in. (431 x 254 x 248 mm)

In order to consistently bring you the highest quality, full-featured products, we reserve the right to change our specifications and designs at any time. FW MURPHY product names and the FW MURPHY logo are proprietary trademarks. This document, including textual matter and illustrations, is copyright protected with all rights reserved. (c) 2022 FW MURPHY. A copy of our typical warranty may be viewed or printed by going to www.fwmurphy.com/warranty.

FW MURPHY PRODUCTION CONTROLS

SALES, SERVICES & ACCOUNTING
4646 S. HARVARD AVE.
TULSA, OK 74135

MANUFACTURING

2151 RANDON DYER ROAD
ROSENBERG, TX 77471

5757 FARINON DRIVE
SAN ANTONIO, TX 78249

DOMESTIC SALES & SUPPORT

FW MURPHY PRODUCTS
PHONE: 918 957 1000
EMAIL: INFO@FWMURPHY.COM
WWW.FWMURPHY.COM

FW MURPHY CONTROL SYSTEMS & SERVICES
PHONE: 281 633 4500
EMAIL: CSS-SOLUTIONS@FWMURPHY.COM

INTERNATIONAL SALES & SUPPORT

CHINA
PHONE: +86 571 8788 6060
EMAIL: INTERNATIONAL@FWMURPHY.COM

LATIN AMERICA & CARIBBEAN
PHONE: +1 918 770 8775
EMAIL: INTERNATIONAL@FWMURPHY.COM

SOUTH KOREA
PHONE: +82 70 7951 4100
EMAIL: INTERNATIONAL@FWMURPHY.COM



FM 668576 (San Antonio, TX - USA)
FM 668933 (Rosenberg, TX - USA)



FM 523851 (China)

TS 589322 (China)