

Installation of 4-1/2 (114 mm) Dial Level Gage

Model Series: OPLHG, OPLHAGS, OPLHFG, OPLHAFGS, OPLHGE, OPLHAGES, OPLHC, OPLHACS, OPLHFC, OPLHAFCS, OPLHCE, OPLHACES, OPLHBP, OPLHABPS, OPLHBPE and OPLHABPES

Please read the following instructions and warnings before installation. Visually inspect the product for any damage that may have occurred during shipping. General information and instructions are intended for all 4-1/2 in. (114 mm) dial level models.

OPLHC, OPLHFC and OPLHCE gage instruments use a bronze bourdon (C-Tube) tube sensing element. All feature adjustable high and low limit contacts that close to common to operate a shutdown, alarms, automation processes, etc. Model OPLHC has a flange case for wall or surface mounting. Models OPLHFC and OPLHCE are for panel mounting. Sensing is 1/4 NPT male.

OPLHACS, OPLHAFCS and OPLHACES gage instruments use a 300 series stainless steel port and bellows as the sensing element. All have the same adjustable contact arrangement as the OPLHC family. OPLHACS has a flanged case for wall or surface mounting. Models OPLHAFCS and OPLHACES are for panel mounting. Sensing is 1/4 NPT female.

OPLHBP, OPLHABPS, OPLHBPE, and OPLHABPES are the same as OPLHC and OPLHACS families and include a built-in latching relay available for 12 VDC, 24 VDC, 24 VAC or 120 VAC. Suitable for on/off or start/stop control.

OPLHG, OPLHGE, OPLHAGS, OPLHAGES and OPLHAFGS are indicating only (without switch contact) versions of the above models.

Warnings	<p>Before beginning installation of this product:</p> <ul style="list-style-type: none"> • Disconnect all electrical power to the machine • Make sure the machine cannot operate during installation • Follow all safety warnings of the machine manufacturer • Read and follow all installation instructions
Precautions	<ul style="list-style-type: none"> • Do NOT exceed rated level range. • Dope or use teflon tape on connection threads • Do not block the inlet orifice with pipe dope/sealant • For direct mount into the process, a vertical or ninety degree mounting is recommended • Use wrench on shank to tighten or loosen connection • Do not overtighten the unit • Do not twist case when screwing the unit into the process, this will damage internal components and will void the warranty • Use shock mounts as necessary to protect from vibration



* Selected configurations are CSA approved. Consult factory for details.

** Selected configurations are third party listed. Consult FW Murphy for details.

IMPORTANT: Gages are pre-calibrated in feet of static head above gage connection. If gage is installed at an elevation higher or lower than tank bottom the gage pointer must be reset for proper level indication. (See Adjusting Limit Contacts and Gage Pointer section.)

Specifications

Case: Die cast aluminum

Contacts: See typical wiring information

Movement: 300 series stainless steel; geared

Sensing connections:

OPLHG, OPLHFG, OPLHGE, OPLHC, OPLHCE, OPLHFC, OPLHBP, OPLHBPE: 1/4 NPT (male)

OPLHACS, OPLHACES, OPLHAGS, OPLHAGES, OPLHABPS, OPLHABPES, OPLHAFCS, OPLHAFGS: 1/4 NPT (female)

-EX Explosion-proof Case Option: 1/4 NPT (female)

Accuracy: ± 2% for the first and last quarters of the scale, the middle half of scale is ± 1 %

Bourdon tube (OPLHC) models: in the 20 ft. (6 m) range have an accuracy of 3% full scale

OPLHAC (Bellows) models: 0-5' 3% full scale, 0-10' 2% full scale

Dial: 4-1/2 in. (114 mm), white on black background

Conduit: Square case: 1/2 NPT, conduit

Round case: Optional 1/2 NPT male (with "ES" option)

Overrange: Do not exceed 10% above full range

Case Mounting

Wall Mount

Flanged case design intended for wall mount. Shown with shock mounts (optional).

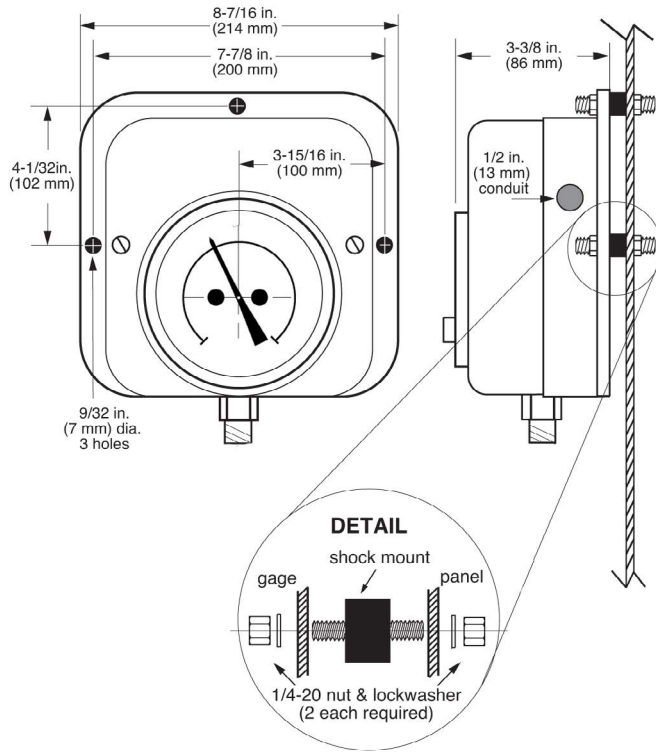

Flush Mount

A round case design to be mounted within a panel from 1/32 in. (1 mm) to 1/8 in. (3 mm) thick.

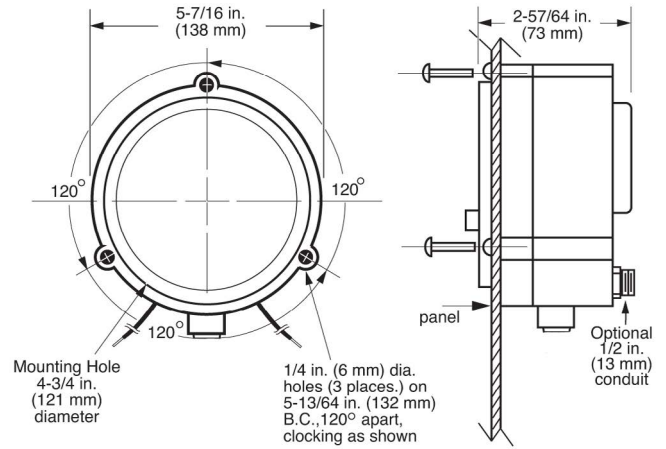

Explosion-proof Case Mount

Explosion-proof case can be mounted from face or rear.

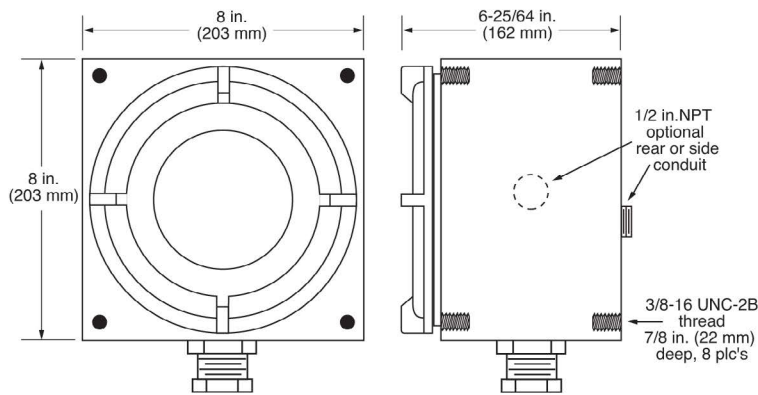

Flush mount/Wall mount

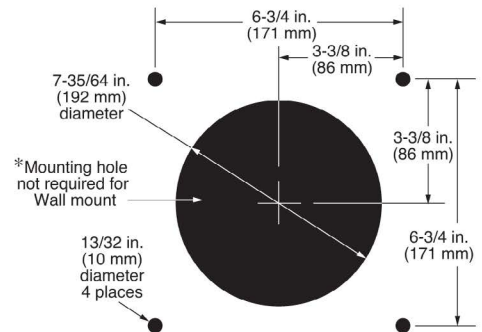

Installation Instructions and Options

IMPORTANT: Gages are pre-calibrated in feet of static head above gage connection. If gage is installed at an elevation higher or lower than tank bottom the gage pointer must be reset for proper level indication. See Adjusting Limit Contacts and Gage Pointer section.

Direct Mount

1. Connection should be made near the bottom of the tank, but above sludge level. See *Above Ground Tank* illustration.
2. The gage connection can be into side or bottom of the tank.
3. After initial installation Stick tank to determine level and reset pointer to that level. See Adjusting Limit Contacts and Gage Pointer section.

Bubbler System for Above/Underground Tanks

1. Connect a level sensor tube to gage instrument. See *Below Ground Tank* and *Direct and Remote Tank* illustrations.
2. Keep sensing tubing above sludge level. Keep connections away from a suction line of the pump. A consistent air flow through the tubing is suggested and will increase the accuracy of the unit. A flow control should be used to limit the flow of air. There should be a constant flow of air. Too high of a rate of air flow will cause the reading to have errors showing the tank level to be higher than it is.

NOTE: Minimum pressure regulator setting in psi= maximum gage instrument range in feet of head x conversion factor (example: 0.4335 for fresh water).

3. After initial installation, Stick tank to determine level and reset pointer to that level. See Adjusting Limit Contacts and Gage Pointer section.

Above Ground Tank

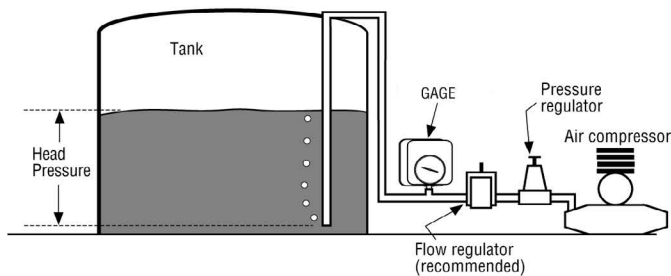

Below Ground Tank

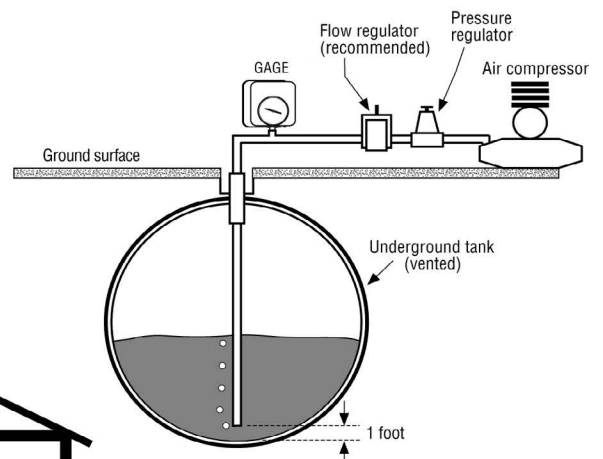

Direct and Remote Tank

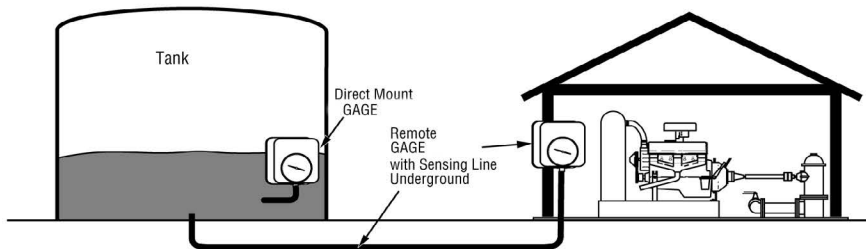

Adjusting Limit Contacts and Gage Pointer

Limit Contact Adjustments

Facing the dial, left side knob is Low limit contact. Right side is High limit contact.

To set limit contact, turn the knob to the desired point on the scale.

Limit Contact Wiping Feature (SPL)

The force of pointer causes the flexible contact arm (A) to tilt resulting in a wiping action (D). This clears away film or corrosion formed on the contact surfaces.

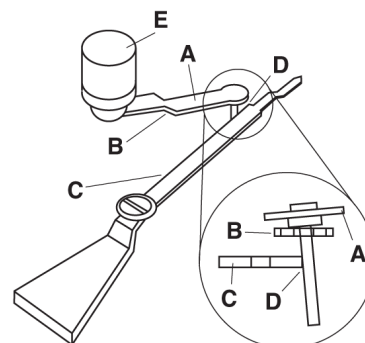

- A. Contact arm-flex
- B. Contact arm
- C. Pointer Contact
- D. Initial point of contact
- E. Limit contact knob

Gage Pointer Adjustments

IMPORTANT: To adjust the gage pointer for high or low elevated tanks, subtract the tank elevation from the gage reading to determine the actual tank reading.

To reset to zero or to a known value proceed as follows:

1. Turn off power. Remove the snap ring and the lens/contact assembly (or open hinged cover).
2. Hold the pointer hub with thumb and forefinger then turn screw to desired point. Avoid touching the gold flashed, silver contact areas. See DETAIL "A".
3. Replace lens contact assembly and snap ring (or close hinged cover), and turn on power.

NOTE: Span adjustments and recalibration must be performed by an authorized mechanic or return the unit to factory.

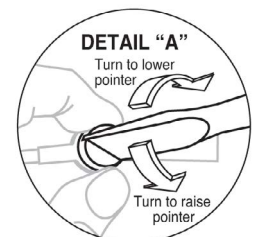

Operation Test Instructions

For All Models

- Operational test(s) are performed after the unit is properly installed and wired.
- When pressure (level) is applied to the instrument, the pointer will travel upscale in a clockwise direction. Adjust the contacts so that neither is touching the pointer.
- Test each limit contact separately by turning it so that it touches the pointer. This should operate the control circuit or device; Example: start a pump on high tank level and stop it on low tank level.
- When desired operation is verified, set the adjustable contacts at the low and high levels.
- For the OPLHC, OPLHCE, OPLHACS, and OPLHAES models, to maintain the NEMA 3R rating, tighten and torque the two cover screws to 27 to 35 in-lbs. after installation and testing are completed.

Typical Electrical Diagrams

WARNING

Perform the wiring operation with the power source OFF. Make sure the voltage and current requirements are within the gage ratings. Before wiring determine voltage and polarity for the application. Use the appropriate wire size. All connections should be made using a spade (forked) or ring terminals. For pigtail connections use wire nuts. Conduit is recommended to protect wires from damage.

OPLHC, OPLHFC, OPLHCE, OPLHACS, OPLHAFCS and OPLHACES

Contact Ratings: 1 SPDT, Center off; 2 A, 30 VDC, 0.1 A, 125 VAC pilot duty.

Square Case Version

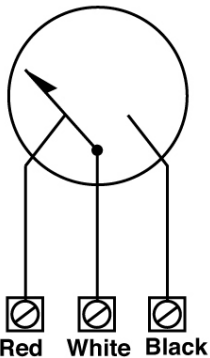

Round Case Version

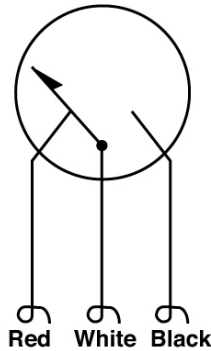

NOTE: Diagrams above show the pointer in the at rest (shelf) position.

BP Versions

Contact Ratings: SPDT dry relay contacts; 10 A, 125 VAC.

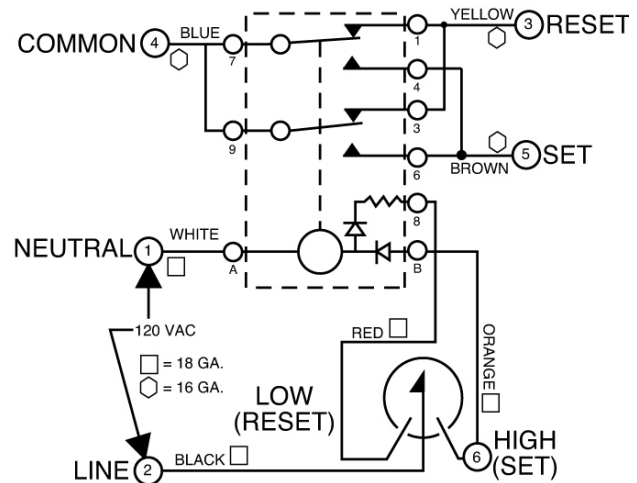

NOTE: Diagram shown with the pointer in the at rest (shelf) position.

Transformer Relay Assemblies

For higher voltages the FW Murphy TR Assemblies can be used in conjunction with any Swichgage® instrument.

All Trademarks and service marks used in this document are the property of their respective owners.

FW MURPHY PRODUCTION CONTROLS
SALES, SERVICES & ACCOUNTING
4646 S. HARVARD AVE.
TULSA, OK 74135

MANUFACTURING
2151 RANDON DYER ROAD
ROSENBERG, TX 77471
5757 FARINON DRIVE
SAN ANTONIO, TX 78249

DOMESTIC SALES & SUPPORT

FW MURPHY PRODUCTS
PHONE: 918 957 1000
EMAIL: INFO@FWMURPHY.COM
WWW.FWMURPHY.COM

FW MURPHY CONTROL SYSTEMS & SERVICES
PHONE: 281 633 4500
EMAIL: CSS-SOLUTIONS@FWMURPHY.COM

INTERNATIONAL SALES & SUPPORT

CHINA
PHONE: +86 571 8788 6060
EMAIL: INTERNATIONAL@FWMURPHY.COM

LATIN AMERICA & CARIBBEAN
PHONE: +1 918 770 8775
EMAIL: INTERNATIONAL@FWMURPHY.COM

SOUTH KOREA
PHONE: +82 70 7951 4100
EMAIL: INTERNATIONAL@FWMURPHY.COM



FM 668576 (San Antonio, TX - USA)
FM 668933 (Rosenberg, TX - USA)



FM 523851 (China)

TS 589322 (China)